

**STATE**  
**LIBRARY**  
**QUEENSLAND**



STATE  
LIBRARY  
QUEENSLAND

# 3D Printer Induction

The Edge





# Acknowledgement of country

We acknowledge Aboriginal and Torres Strait Islander peoples and their continuing connection to land and as custodians of stories for millennia.

We respectfully acknowledge the land on which we all meet today, and pay our respects to elders past, present and emerging.



Using the State Library 3D printers, you can turn a digital 3D model into a plastic object.

In this induction you will learn the basics of 3D modelling with Tinkercad and how to print your own model—including how to prepare the file for printing and clean up the printed object.

Once you've completed this induction you can book and use the State Library of Queensland's 3D Printers at The Edge during Open lab hours.

**Open Lab** sessions are a chance to meet up with like-minded makers and tinkerers at The Edge with facilitators to support your creative needs in the space.

Bookings are required to use the equipment and you will be able to book with your SLQ account once you have completed the relevant induction.

**Wednesdays & Saturdays 12:00pm – 5:00pm**

**Thursdays 1.30pm – 8:00pm**

For more info and to book, head

<https://www.slq.qld.gov.au/visit/spaces/edge>

# Induction Summary



# Login Details

Password on the computer is  
**Edgeuser**

Sign up for a Tinkercad account  
[Tinkercad.com](https://www.tinkercad.com)

Enroll in the Learning Management System  
with your SLQ membership account  
[Inductions.slq.qld.gov.au](https://inductions.slq.qld.gov.au)



# Equipment Overview

## What is a 3D PRINTER?

- Allows for 3D printing which is the construction of a three-dimensional object. It does this through material being deposited, joined or solidified under computer control.
- The Edge currently offers patron access to five Prusa model MK4 printers. These printers have replaced our older Prusa i3 MK3S+ printers and offer improved ease of use.

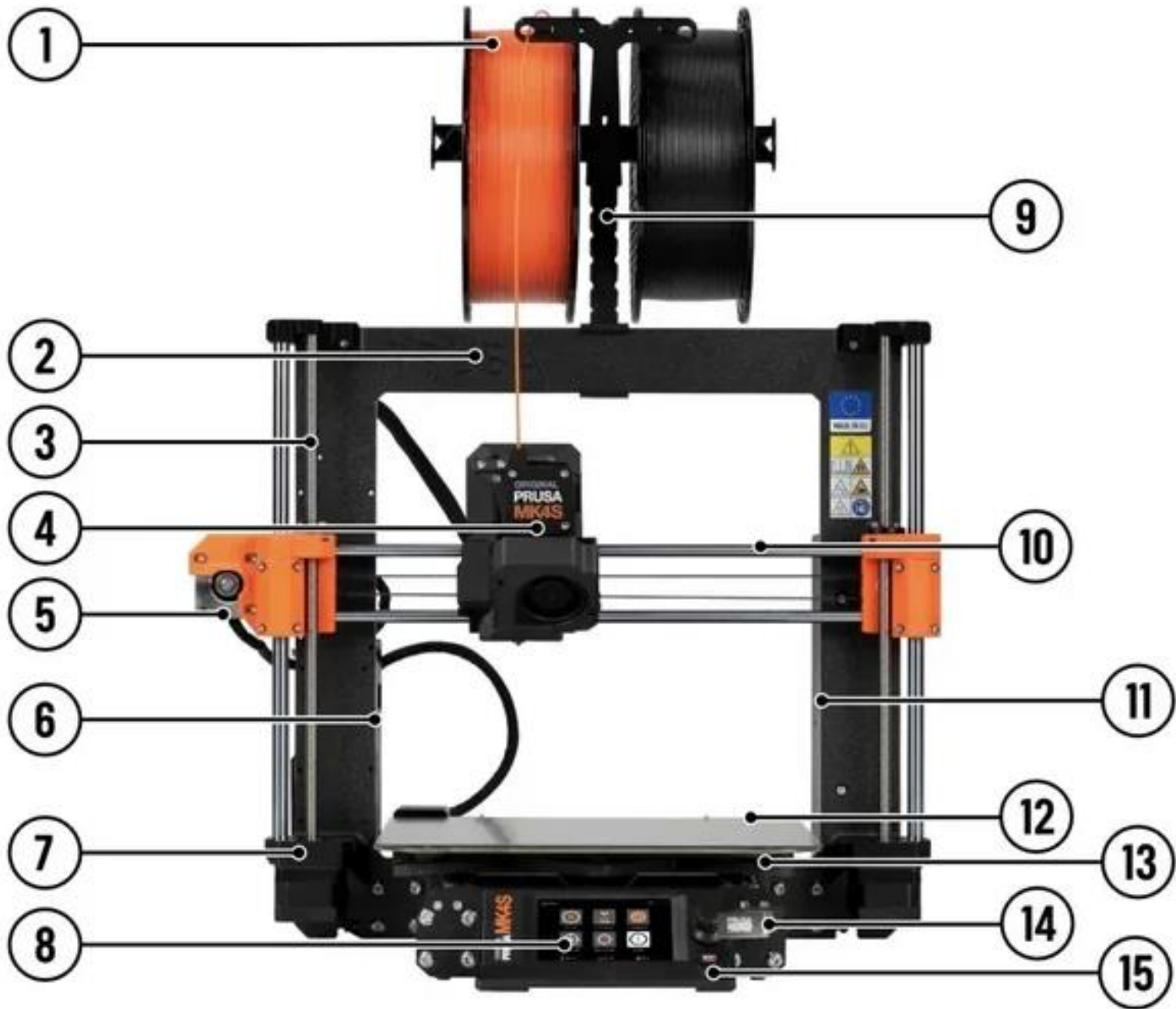

# Machine Overview

1. **Filament spool** – will typically be located in dryer.
2. **Frame** – rigid aluminum structure.
3. **Z-axis** – threaded and smooth rods, moved by two stepper motors, raise and lower the Nextruder.
4. **Nextruder** – direct-drive extruder for precise filament control.
5. **X-axis stepper motor** – drives the Nextruder’s horizontal motion.
6. **Electronics box** – houses the xBuddy board, with Ethernet and Wi-Fi ports at the rear.
7. **Base**
8. **LCD screen** – touchscreen interface for control and configuration.
9. **Spool holder** – not currently in use.
10. **X-axis** – horizontal assembly with rods, motor, belt, and plastic parts that guide the Nextruder left to right.
11. **Power Supply Unit** – custom 240 W Delta PSU with Power Panic.
12. **Print sheet** – magnetic PEI sheet for adhesion and easy part removal.
13. **Heatbed** – proven design with embedded magnets for removable sheets.
14. **USB port & drive** – used for G-code printing and firmware updates.
15. **Rotary knob & reset button** – secondary control inputs.

# Getting Started



- Book a 3D printer.
- Import your STL, OBJ, or 3MF into an installation of PrusaSlicer that has been configured by an Open lab Facilitator.
- Facilitators will make recommendations regarding part orientation, support placement, layer height, and other parameters.
- The Facilitator will step through the checklist on the Open Lab 3D Print Job Form and approve your job.
- Depending on job duration and/or filament preference, your job may be placed on a printer immediately or placed in a job queue.



# HEALTH & SAFETY

- Electricity
- Fire
- Respiratory
- Crush injury
- Isopropyl  
(eyes/breathing/flammable)

Check the safe operating procedures regularly and ask a staff member for help if you have any problems or concerns.

# Designing for 3D Printer

## **Fusion 360**

### Pros

- Powerful professional CAD, CAM, CAE software
- Lots of good tutorials online
- Great for designing close tolerance mechanical parts
- Free hobbyist licence available

### Cons

- A lot to get your head around when starting out
- Full version relatively expensive (but not as expensive as others)

# Designing for 3D Printer

## Meshmixer

### Pros

- Free
- Great software for sculpting 3D
- Good for repairing models made in other programs

### Cons

- Probably want to try something more intuitive first to get your head around the concepts

# Designing for 3D Printer

## Blender

### Pros

- Free and open source
- Great software for all types of 3D modelling and animation
- Lots of tutorials and guides online

### Cons

- Probably want to try a simpler software first to get your head around the concept of 3D design

# Designing for 3D Printer

## TinkerCAD

### Pros

- Free
- Great intuitive software for getting started
- Browser based

### Cons

- Experienced designers might get frustrated with the lack of features

## Start Tinkering

How will you create your account?

Sign up with Email

 Sign in with Google

 Sign in with Apple

[More sign in options...](#)

Already have an account?

[Sign In](#)

# TinkerCAD

Let's have a go!

- Head to the internet and navigate to TinkerCAD.com
- Create a free account using an email address

Auto-generates a file name  
double click to type in  
something meaningful

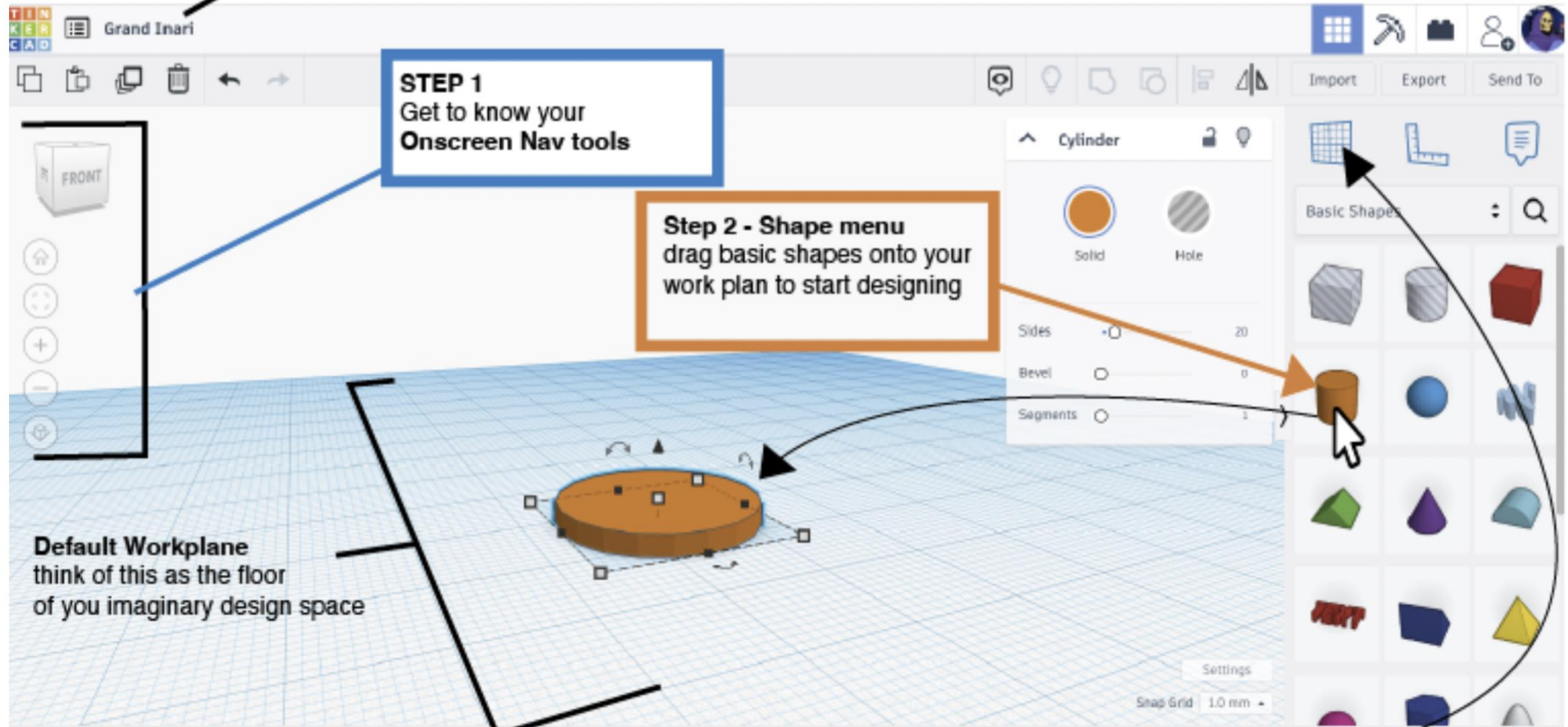

**STEP 1**  
Get to know your  
Onscreen Nav tools

**Step 2 - Shape menu**  
drag basic shapes onto your  
work plan to start designing

**Default Workplane**  
think of this as the floor  
of you imaginary design space

but you can also use this tool  
to place a workplane on any face of an object

# Navigating the 3-dimensional space

## Moving around

- Zoom in and out using the scroll wheel

## Pan & Tilt

- Right click and drag to change the aspect of your view or
- Click and drag the Cube device to rotate you view angle
- If you get lost click the **home icon** and it will take you back to the default view

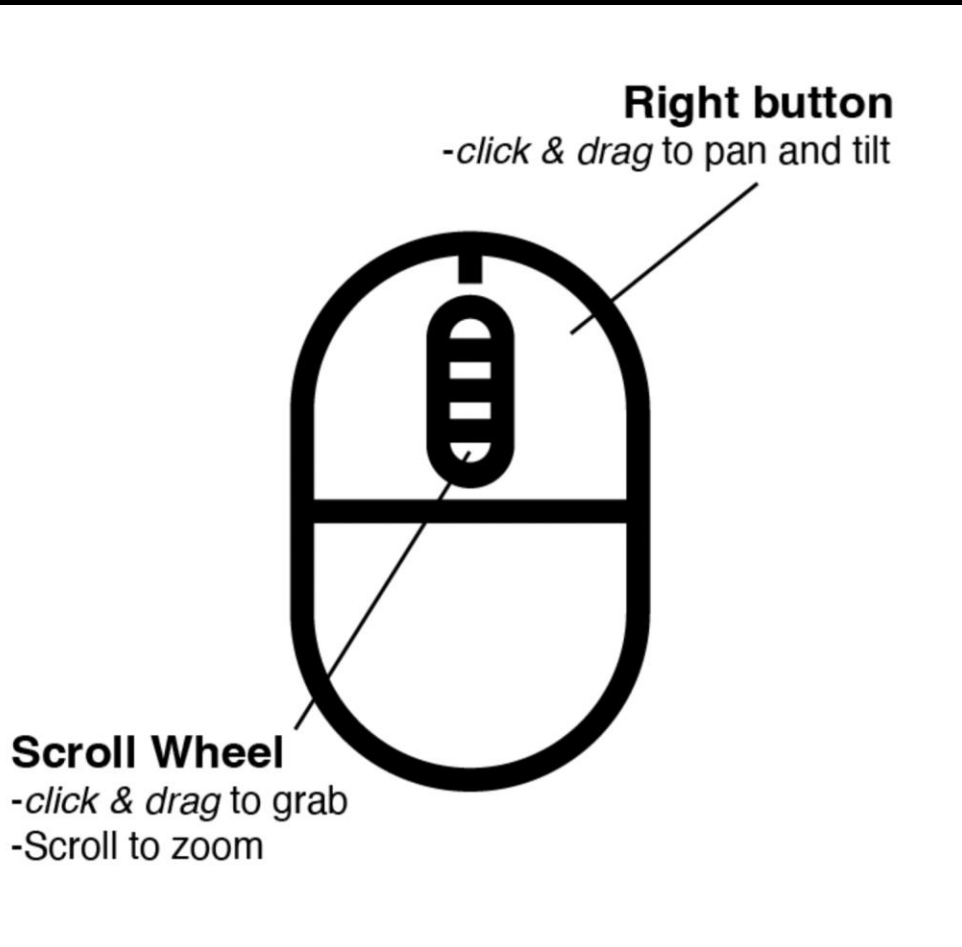

# Moving and manipulating shapes

## Select

- Using the left click (hold shift select multiple objects)
- Or left click and drag a selection box around multiple objects

## Resizing

- Left click and drag the black or white handles to resize your shapes
- Hold the SHIFT key to constrain proportions
- Left click and drag the black cone to change the elevation of the shape in relation to the work plane

## Moving

- You can nudge a selected object around the x & y axes with the arrow keys

## Rotate

- Left click and drag the curly one of the 3 arrows to rotate an object, you can also type in an angle once it is highlighted.

## Ruler

- Drag the ruler out onto the workplace to resize or arrange shapes using typed in dimensions

# Make a complex shape

## Make a complex 3D shape in 4 steps

1

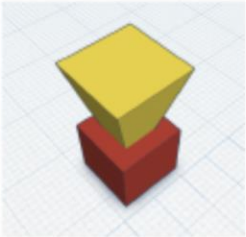

Start with 2 shapes

2

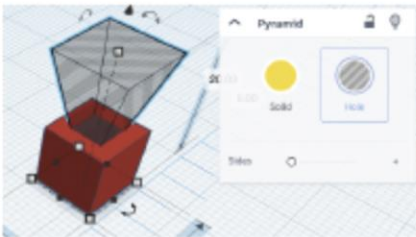

Select one shape and make it a hole

3

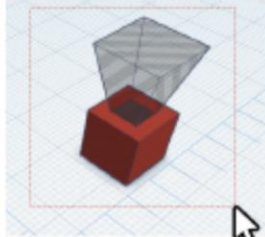

now select both  
by dragging a box  
around them

4

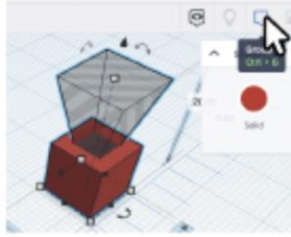

and hit the group button

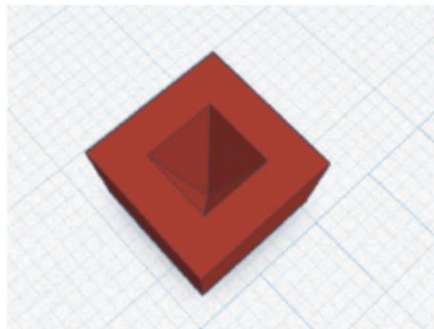

## Grouping solids and holes

- You can make complex shapes by combining and subtracting the primitive (basic) shapes using the group tool.
- Select the objects you want to combine
- And then hit the group button

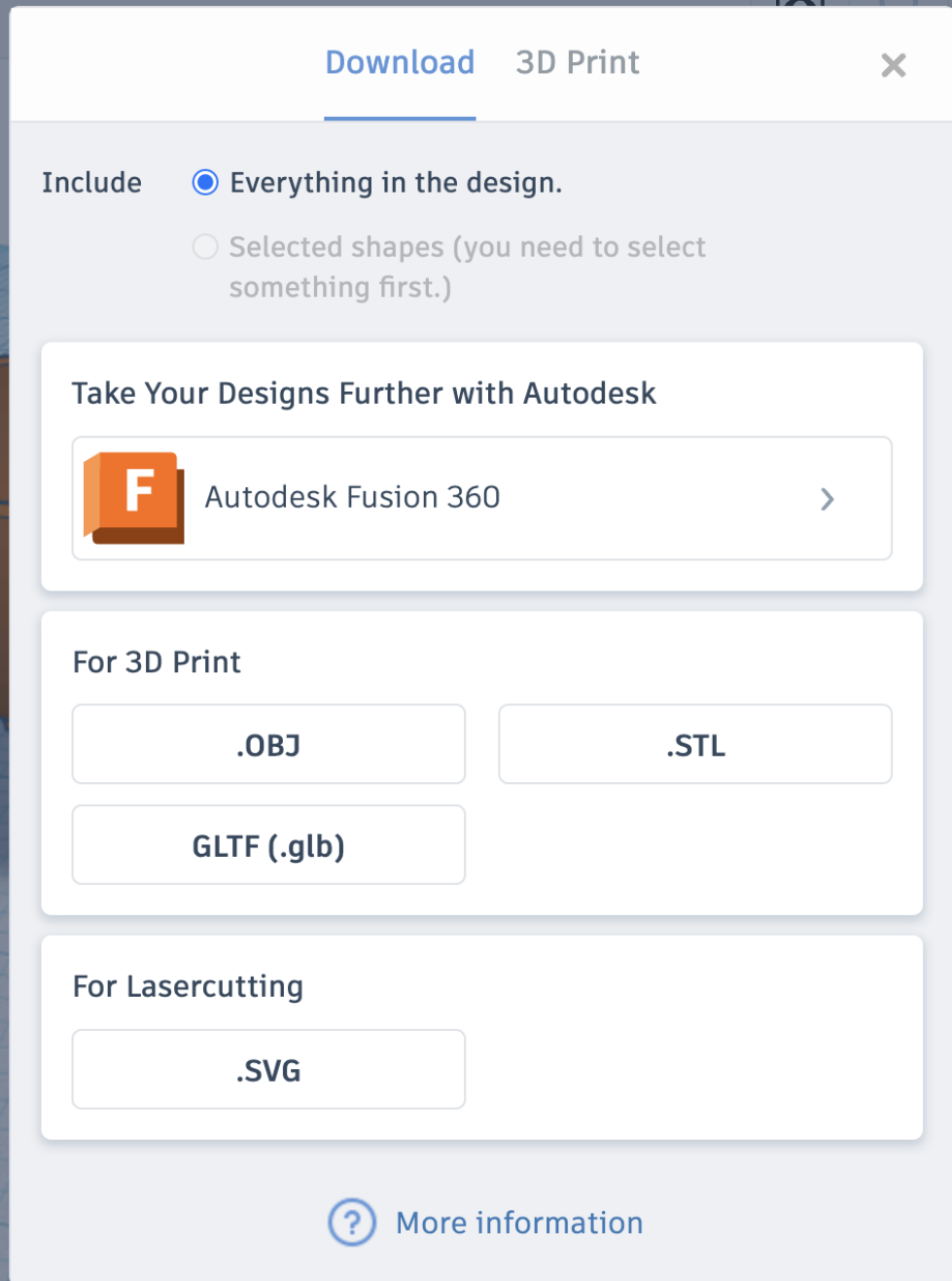

# Exporting

- Hit the export button and select STL
- Save to your desired folder
- Open file up in PrusaSlicer using one of our facility computers. The software will be configured correctly on our computers.

# What is Slicing?

The act of converting a 3D model into a set of instructions for 3D printers is called **Slicing**. It is the intermediate and most important step in the process of 3D printing and where The Edge staff will need to check your settings.

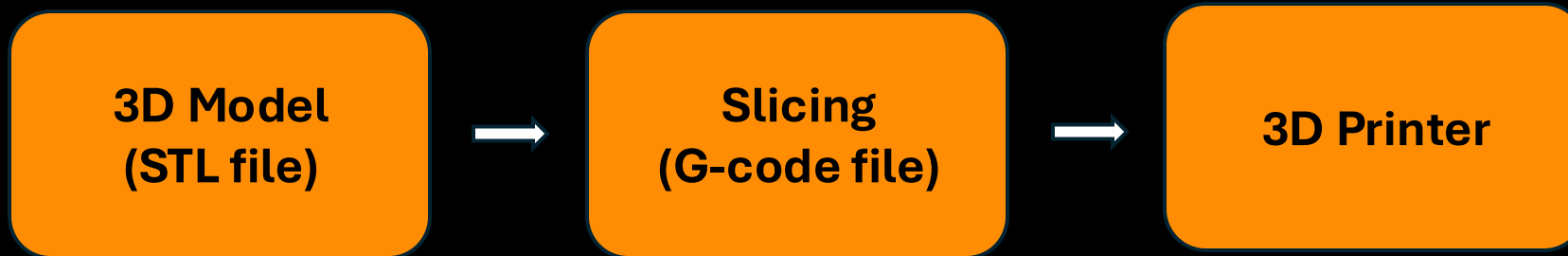

These are some of the main types of settings that can be controlled in a slicer software -

- Print Settings: quality and speed.
- Filament Settings: type of filament etc.
- Printer settings: the model of printer etc.
- Supports: added parts that support overhanging or bridge structures when printing.
- Infill: the internal structure (density/fullness) of a 3D printed part.

# Slicing with PrusaSlicer



When choosing your print settings, you need to weigh up some priorities

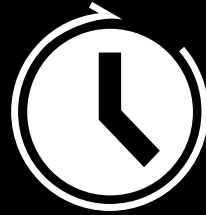

Does it need to be a quick print?

Or do you have time for high quality outcome?



What percentage infill do you need?

Do you need to print support?



How much filament will this use?

Would it be more time or material efficient to cut up your model?

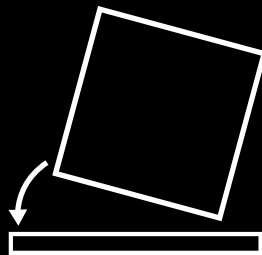

Or maybe reorienting it will save time, plastic, support and or clean up?

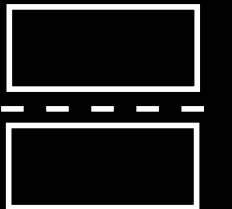
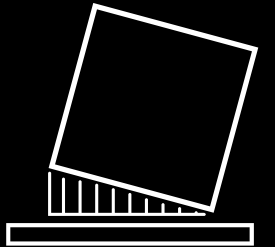

# Further info on Supports

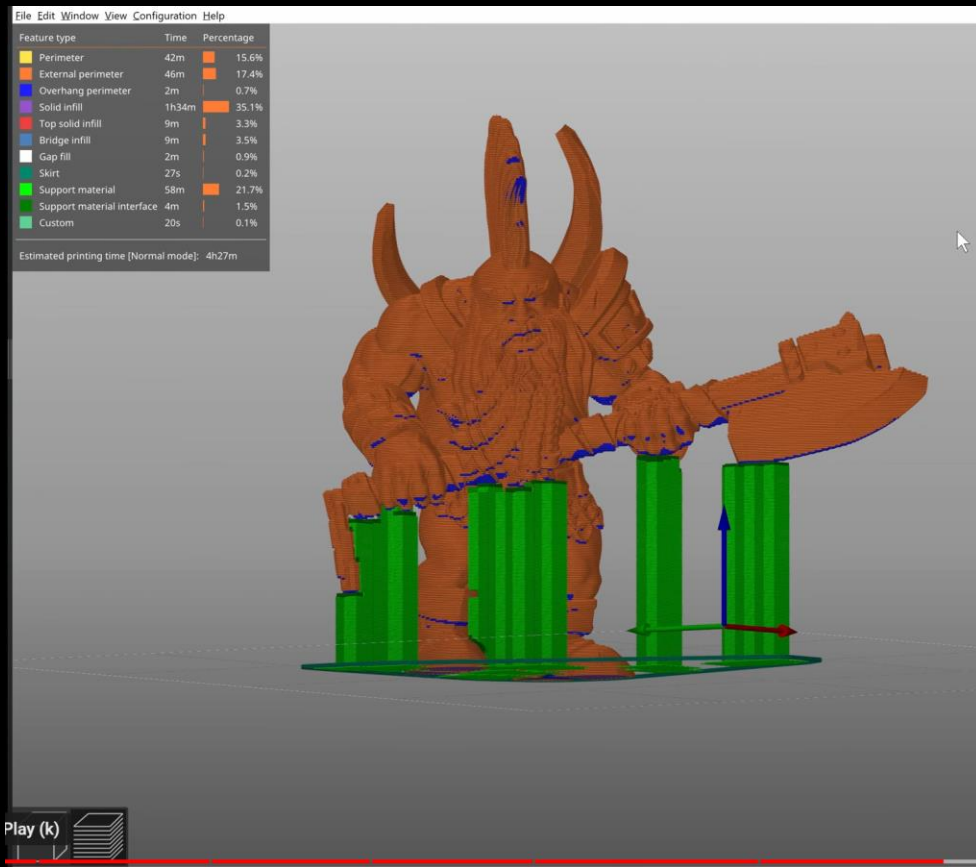

Source [Jakub Kočí](#)

3D printers work by layering plastic to create a 3D object. Each new layer must be supported by the one beneath it. If part of your model starts in mid-air and is not supported by anything below, you need to add an additional support structure to ensure a successful print.

Consider if you are able to alter the orientation of the model or split into multiple parts to reduce overhangs and the amount of supports generated.

PrusaSlicer can both detect areas that need supports and generate them in these places automatically.

The Paint On support option also works great to manually choose the places you want to add supports to.

# Further info on Infill

There are a few factors when choosing an infill pattern, listed below, and you can read up on these more on the [Prusa website](#).

Prints (even mechanical parts) rarely benefit from infill over 20%, as uneven cooling can occur on more complex infill which leads to distortions and delamination.

**Print speed:** How quickly can the pattern be printed?

**Density:** How much filament is used to create the pattern?

**Visuals:** How does the pattern look when using transparent filament? How does it look if the model is exposed?

**Support for top layers:** How well will the top layer of a print be supported?

**Flexibility:** How flexible will the print be with the chosen infill pattern?

**Filling:** How suitable is the pattern for filling with resins or other substances? This is especially important for parts that may be used as molds for casting.

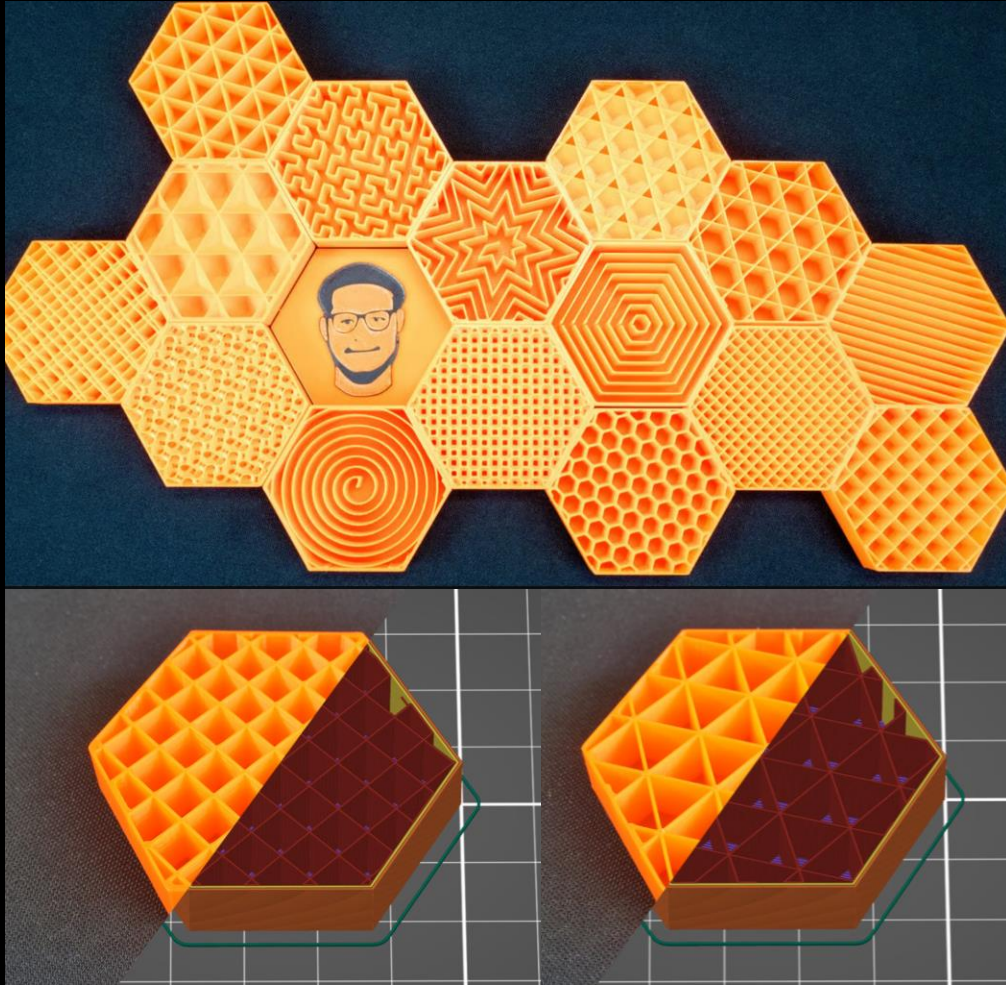

Source [Jakub Kočí](#)

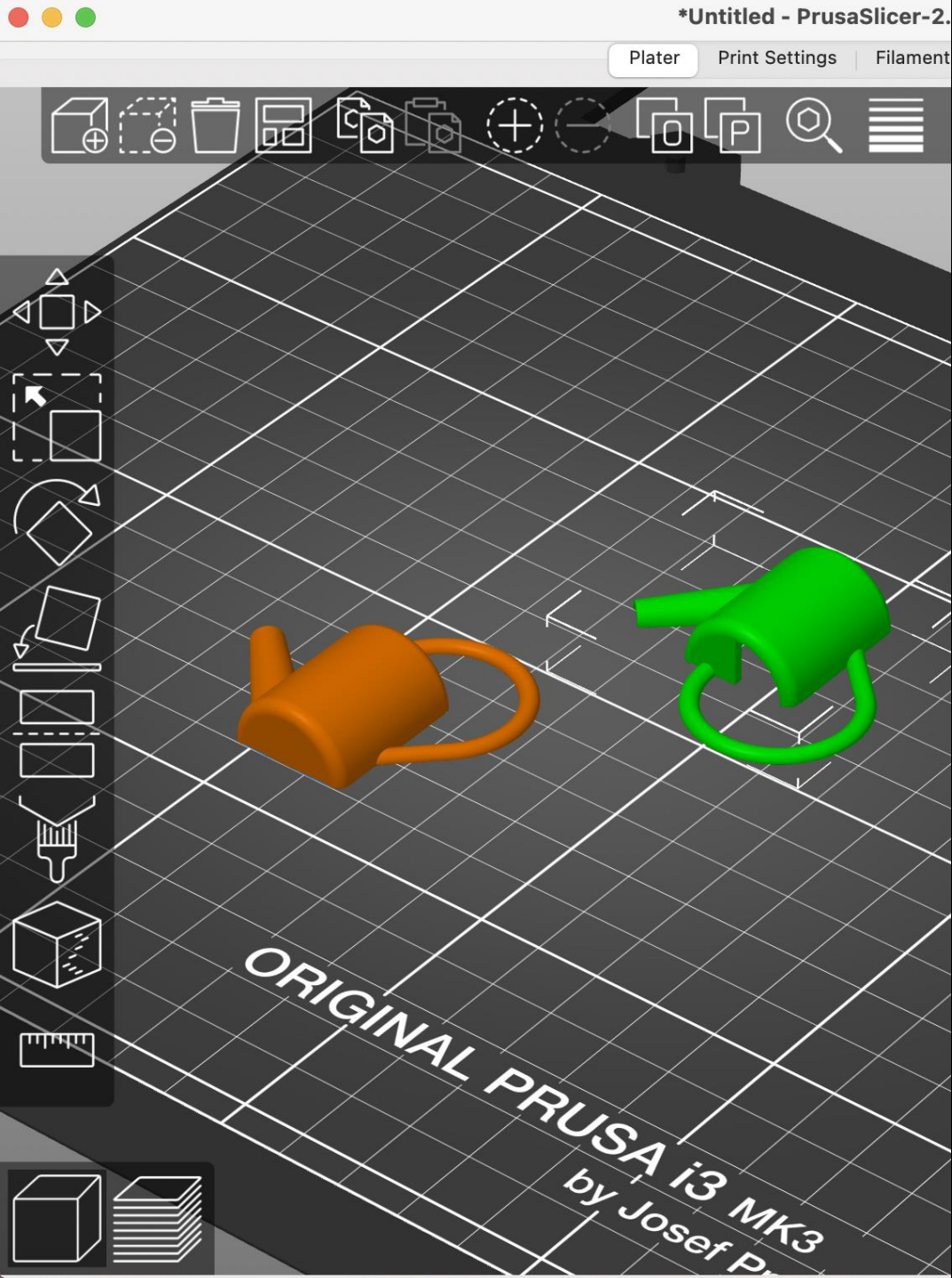



# Slicing with PrusaSlicer



- Open the **PrusaSlicer** application. If you see the pop-up 'Configuration Update' is available, click to install the update before proceeding further.
- Use the **Add** button to import your model/s into PrusaSlicer.
- **Delete /Delete All** buttons to remove models.
- Use **Move, scale, rotate, Place on Face** and **cut tools** to prepare the model to printing in the most efficient/effective orientation.

Simple



### Print settings:

  0.20mm QUALITY

### Filament:

  Esun PLA

### Printer:

  Original Prusa i3 MK3S & MK3S+

Supports:

Infill:   Brim:

### Name

Pot Plant v3.stl\_1



Pot Plant v3.stl\_2



Pot Plant v3.stl\_3



Pot Plant v3.stl\_4



Pot Plant v3.stl\_5



Pot Plant v3.stl\_6



# Slicing with PrusaSlicer

## Print Settings

- Select a **Quality / Speed** setting for your print, the higher the quality, the longer the print will take.
- Select the **filament** that corresponds with the one on the printer (check the machine before you slice).
- Select a **Supports** setting
- Select an **Infill** percentage

# Slicing with PrusaSlicer

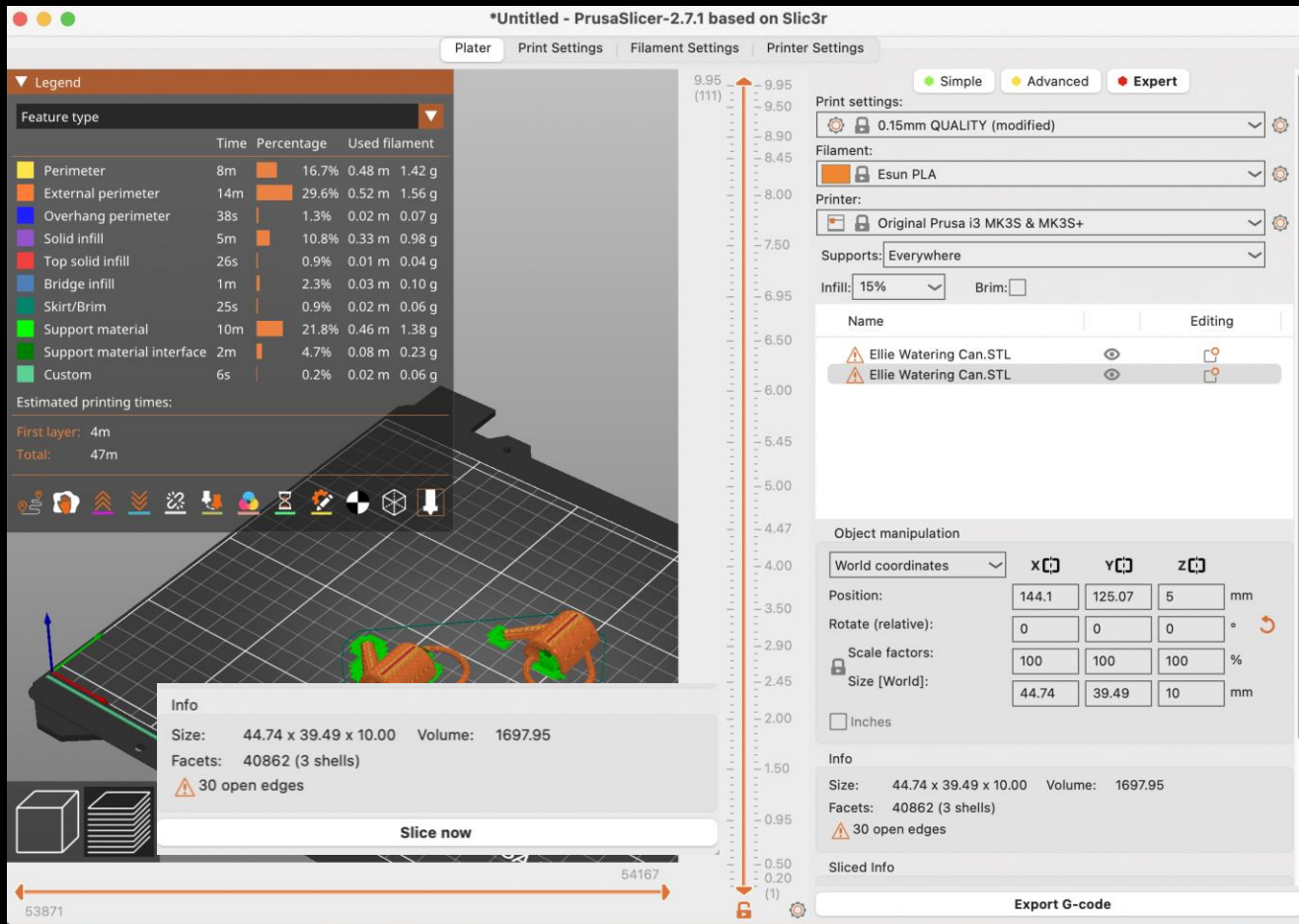

- Click **Slice** to *slice* the model into layers in the Z axis and select **layers preview** to view infill land
- Check the **Sliced Info** for the cost (amount of filament used) and how long it's going to take to print.
- If you are happy with the time and settings, ask a staff member to check over and fill out the print form.
- Generate and export *G-Code* to the SD Card by clicking the **Export G-Code** button.

# Setting up the printer

## STEP BY STEP

After a staff member has approved your slicing, you can head to the 3D printer you have booked to start your 3D print.

1. Turn on the 3D printer (switch located on the back of the Prusa machines)
2. Ensure the printer is set up with the correct filament and build plate.
3. Switch on the extractor under the 3D printer. Each extractor serves 2 printer enclosures. Make sure BOTH the extraction and return air blast gates serving the printer you are using are open. If there is no job on the 2nd printer, ensure the blast gates serving its enclosure are closed.
4. Insert your media (SD card for Mk3s+ or USB thumb drive for the Mk4) into the printer.
5. Navigate to the file on your media by turning the knob on the screen and selecting the correct G-Code file you have prepared. Select by pushing the button. The printer extruder and bed will start heating up. Your print will start when the target temperatures are attained.
6. Monitor the start of the print to make sure it begins with no issues; you can then leave it to print.



# Troubleshooting

## Something is weird or going wrong?

- First reaction should always be *pause the job*
- Remember you can always ask a staff member for help!

## The filament spool doesn't unwind?

- Check spool mounting and rotation
- Ensure filament on spool is able to unwind without binding

## The machine announces an error?

- Refer to the manual for error code explanations
- Check for temperature, connection, or SD card issues

# Common print failures

- Birds nest (filament non-adhesion)
- X and/or Y-axis shift (belt or stepper motor errors)
- Print wholly or partially detaches from build plate
- Blocked nozzle
- G-code encoding error
- Thermal anomaly or runaway (hot end or bed)
- Head impact

# Troubleshooting

## **The print wholly or partially detaches from the build plate?**

- Ensure correct build plate for specific filament type is being used.
- Ensure a clean and level build plate
- Adjust first layer Z height

## **The printer shifts in the x and/or Y axis?**

- Tighten belts and pulleys (staff only)
- Ensure a stable, clear printing environment
- Verify correct print file generation

## **Filament birds nest forms**

- Clean clogged nozzle (staff only)
- Ensure smooth filament path
- Calibrate extruder and temperature settings (staff only)

## **The spool runs out of filament or the filament breaks?**

- Monitor spool and replace before empty (staff only)
- Replace filament with another spool known to be dry (staff only)

See staff for support with any issues labelled Staff only

# Extra resources

## Prusa

<https://www.prusa3d.com/>

<https://blog.prusa3d.com/>

## Thingiverse

Checkout things other people have designed for 3D printing and save yourself a lot of time designing something someone else has successfully made. Remix / customise other people's designs.

<https://www.thingiverse.com/categories>

## Functional Print

Check out the functional solutions people print up on Reddit.

<https://www.reddit.com/r/functionalprint/>

## THANKS FOR ATTENDING

---

Please complete our survey that will be sent out via  
Eventbrite.

Tag us on socials @statelibraryqld

Contact us on [appliedcreativity@slq.qld.gov.au](mailto:appliedcreativity@slq.qld.gov.au)



**STATE**  
**LIBRARY**  
QUEENSLAND



[slq.qld.gov.au](http://slq.qld.gov.au)