

### ACTIVITY 1 - KEY SAFETY TIPS FOR THE FABRICATION LAB

Draw a line to match the safety tip with its explanation



Wear the right safety gear



Clean up as you go



Correctly use the right tool for the job



Always wear appropriate covered footwear



No kids under 12. Sorry!



Ask questions if you have any doubts

### EXPLANATION



It's there for your protection

It's easy to ask and you could prevent an injury

They protect your feet & help prevent slipping

Most injuries come from misusing tools

There is hazardous equipment & substances used in the Fabrication Lab

Accidents happen in untidy spaces

NAME:

DATE:

The aim of The Edge Resource Inductions are to ensure that patrons are equipped with practical skills and knowledge to safely access the range of tools available for public use in the Fabrication Lab. In each of these inductions, an Edge Facilitator will deliver training on the safe and appropriate use of equipment.

The following form serves as a record of your participation, and provides evidence to demonstrate your competent understanding and practical application of the training.

The assessment evidence collected in this Induction will be in three forms: Written Assessment, Peer Assessment (Verbal), and Workshop Facilitator Observations.

If you require any extra assistance to complete this induction please inform your facilitator at the beginning of the session.

### ACTIVITY 2 - IDENTIFY LASER CUTTER COMPONENTS

Using the list of components on the right, identify each part by writing it in the relevant box.

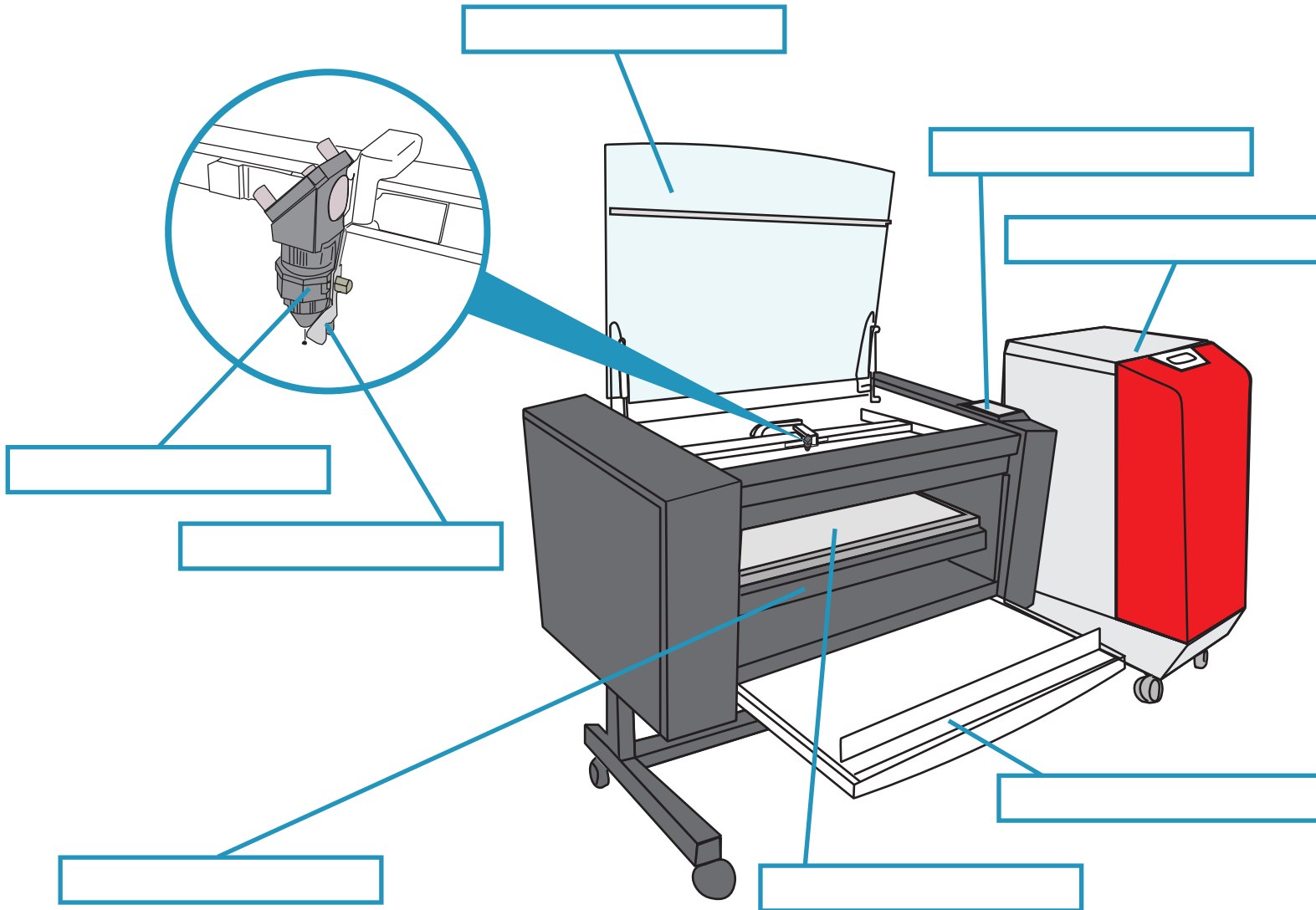

### COMPONENTS

Glass lid

Bed

Focusing Head

Front Door

Honeycomb

HEPA Fume Extractor

Control Panel

Calibration Tool

### ACTIVITY 2 - IDENTIFY CONTROL PANEL FUNCTIONS

Using the list of components on the right, identify each part by writing it in the relevant box.

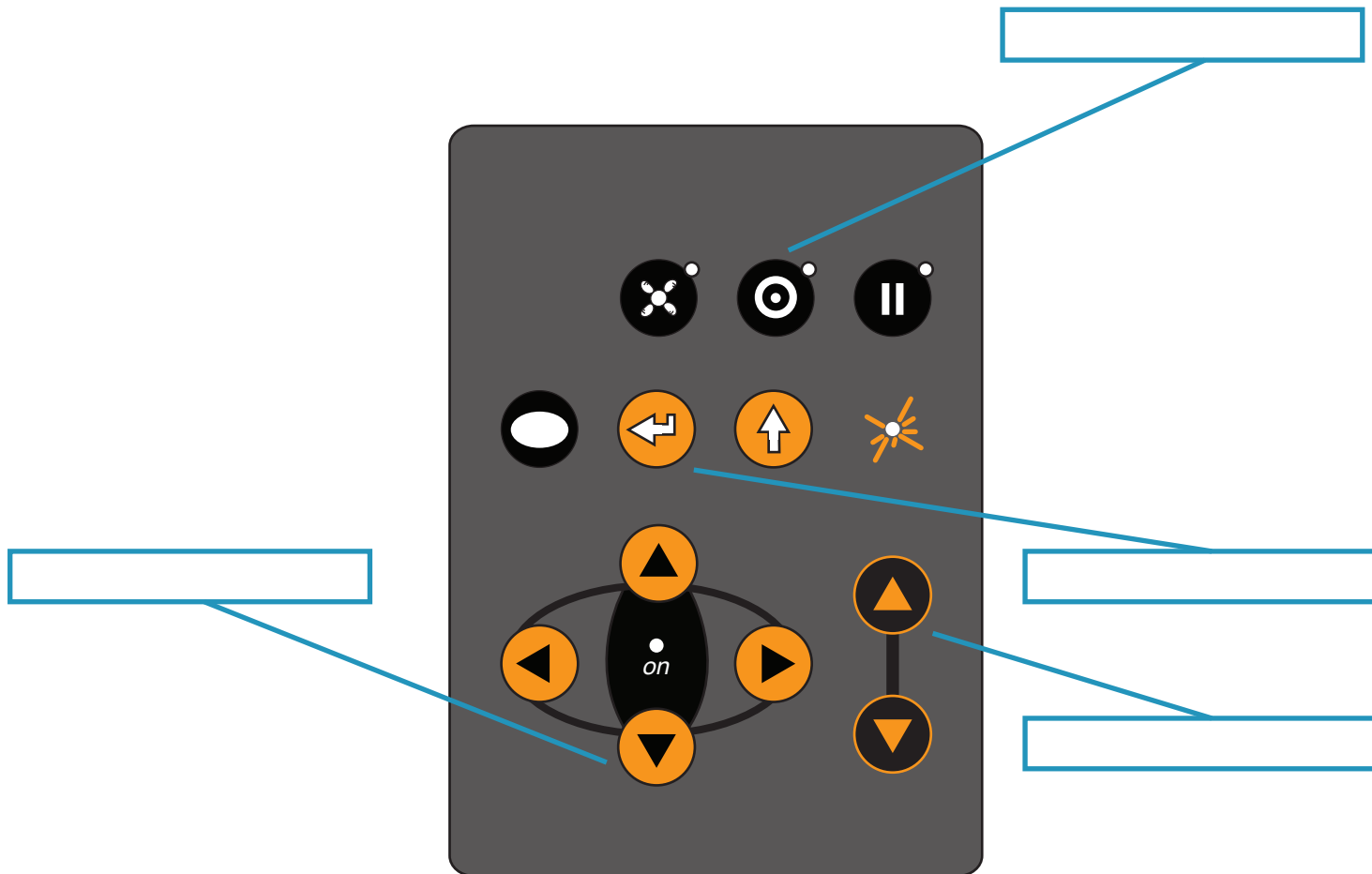

### FUNCTIONS

Move Laser/Focusing Head around in the x & y axis

Start job

Pause job & place in stand by mode

Move bed up & down on the Z axis

### ACTIVITY 3 - IDENTIFY LASER CUTTER SAFETY/OPERATIONAL TIPS

Using the safety tips on the right, identify what component it relates to by writing the safety tip number in the relevant circle.

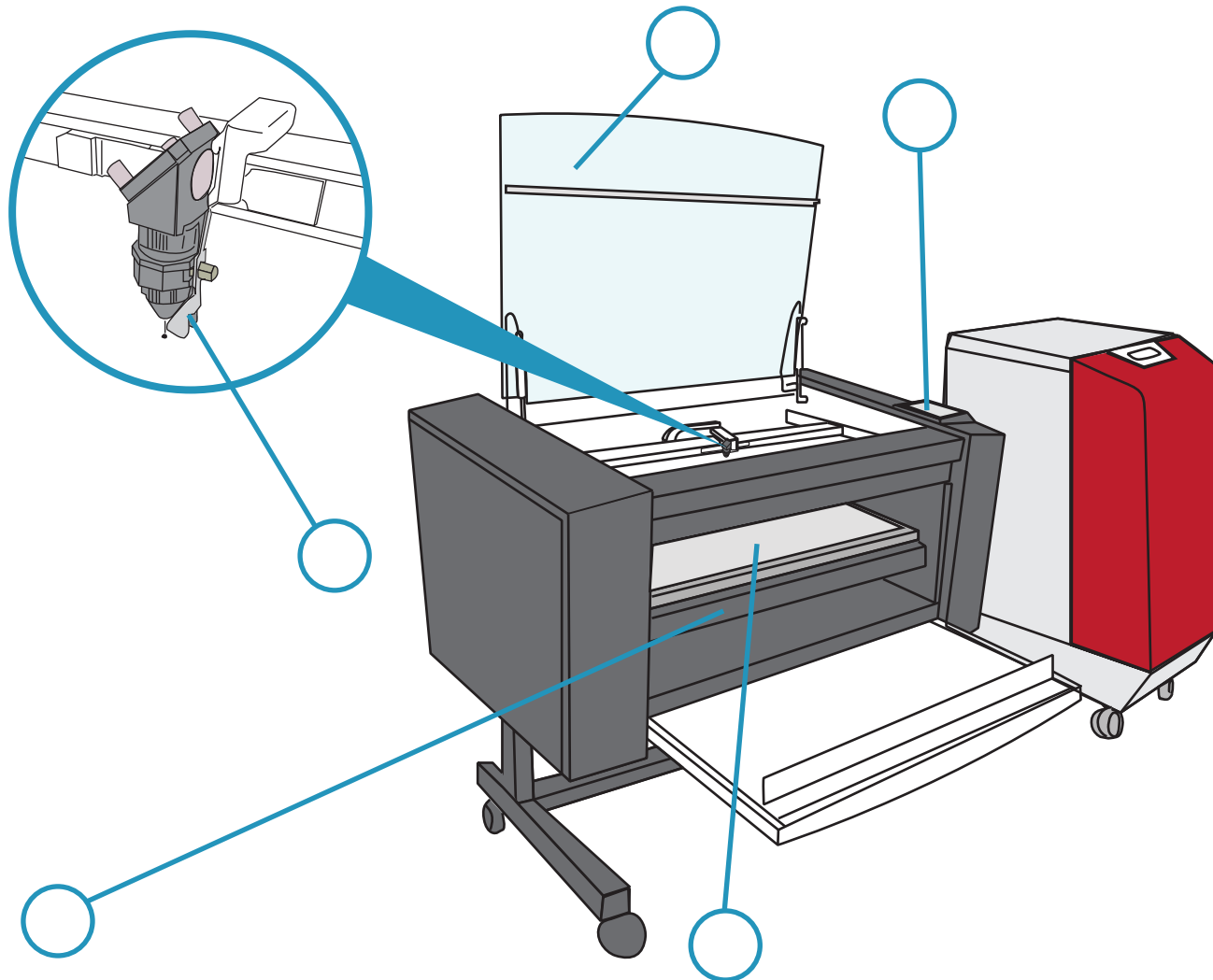

### SAFETY/OPERATIONAL TIPS

- 1 Watch out for head crashes when focusing the laser
- 2 Needs to be cleaned regularly, seek assistance as it's sharp
- 3 Always start your job from the control panel so you can see if anything goes wrong
- 4 Watch out for head crashes when moving the bed
- 5 Lift lid to abort job

### ACTIVITY 4 - LASER WORKFLOW

We have identified 6 stages in the laser cutter process and within each stage is a number of steps. Identify the missing step/s in each stage, and write it in the blank box.

#### 1. PREPARE DESIGN FOR CUTTING

- 1 Import and layout design in Corel Draw
- 2
- 3 Name job and save file

#### 2. PREPARE THE LASER & MATERIAL

- 1 Check thickness of material
- 2
- 3 Align starting point for cut

#### 3. SET LASER PREFERENCES

- 1 Ensure Auto focus is off
- 2 Select the material and thickness
- 3
- 4
- 5 Upload the job to the print manager

### ACTIVITY 4 - LASER WORKFLOW CONTINUED

#### 4. PREFLIGHT CHECK

**1** Check the Laser cutter is clean and ready to cut

**2** Check there is a current Hot Work Permit

**3** Check Honeycomb is correctly seated on the bed

**4** Calibrate the focal distance

**5**

**6**

#### 5. DURING THE CUT

**1** Enter job details into the Machine Log:  
[edgeqld.org.au/laser-cutter-job-log](http://edgeqld.org.au/laser-cutter-job-log)

**2** If your material catches fire **Lift the Lid to abort the job** and seek assistance from the Supervisor

**3**

**4** Avoid looking directly at the Laser. Prolonged staring at laser flash may cause eye strain

#### 6. AFTER THE CUT

### PEER ASSESSMENT

I confirm that the observations of my peer showed active participation in this induction workshop and demonstrated a satisfactory understanding, including competent and safe use of the above tools.

Date	Peer Assessor	Peer Assessor Signature
------	---------------	-------------------------

### FACILITATOR WORKSHOP OBSERVATION

I confirm that the observations made of the participant and active participation in this induction workshop demonstrated a satisfactory understanding, including competent and safe use of the laser cutter.

Date	Edge Facilitator	Facilitator Signature
------	------------------	-----------------------

### PARTICIPANT DECLARATION

I declare the assessment above was my own individual work.

Date	Participant Signature
------	-----------------------