







ACTIVITY 1 - KEY SAFETY TIPS FOR THE FABRICATION LAB

Draw a line to match the safety tip with its explanation

		EXPLANATION
	Wear the right safety gear	It's there for your protection
	Clean up as you go	It's easy to ask and you could prevent an injury
	Correctly use the right tool for the job	They protect your feet & help prevent slipping
	Always wear appropriate covered footwear	Most injuries come from misusing tools
	No kids under 12. Sorry!	There is hazardous equipment & substances used in the Fabrication Lab
	Ask questions if you have any doubts	Accidents happen in untidy spaces

NAME:

DATE:

The aim of The Edge Resource Inductions are to ensure that patrons are equipped with practical skills and knowledge to safely access the range of tools available for public use in the Fabrication Lab. In each of these inductions, an Edge Facilitator will deliver training on the safe and appropriate use of equipment.

The following form serves as a record of your participation, and provides evidence to demonstrate your competent understanding and practical application of the training.

The assessment evidence collected in this Induction will be in three forms: Written Assessment, Peer Assessment (Verbal), and Workshop Facilitator Observations.

If you require any extra assistance to complete this induction please inform your facilitator at the beginning of the session.

ACTIVITY 2 - IDENTIFY 3D PRINTER COMPONENTS

Using the list of components on the right, identify each part by writing it in the relevant box.

Back Side

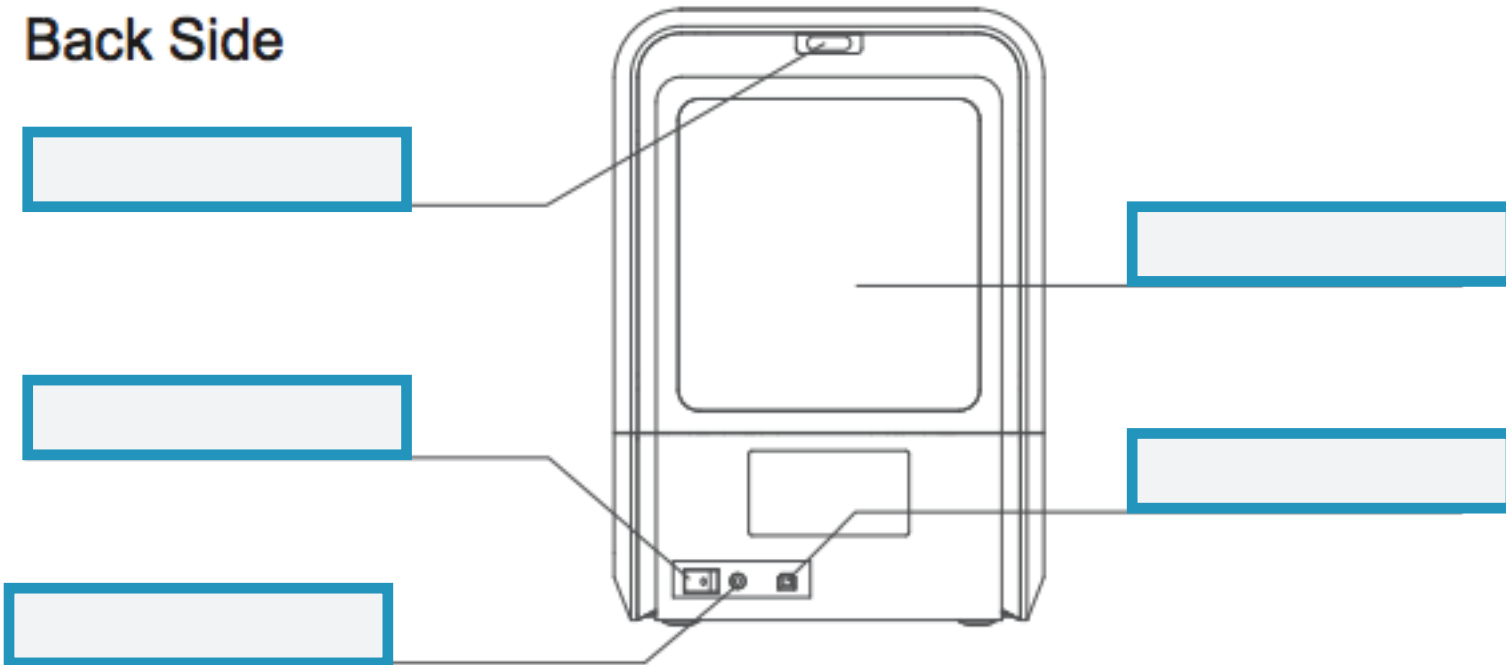

COMPONENTS

Back Door

USB Connector

Filament Insertion Hole

Power Supply Connector

Power Switch

ACTIVITY 3 - IDENTIFY 3D PRINTER COMPONENTS

Using the list of components on the right, identify each part by writing it in the relevant box.

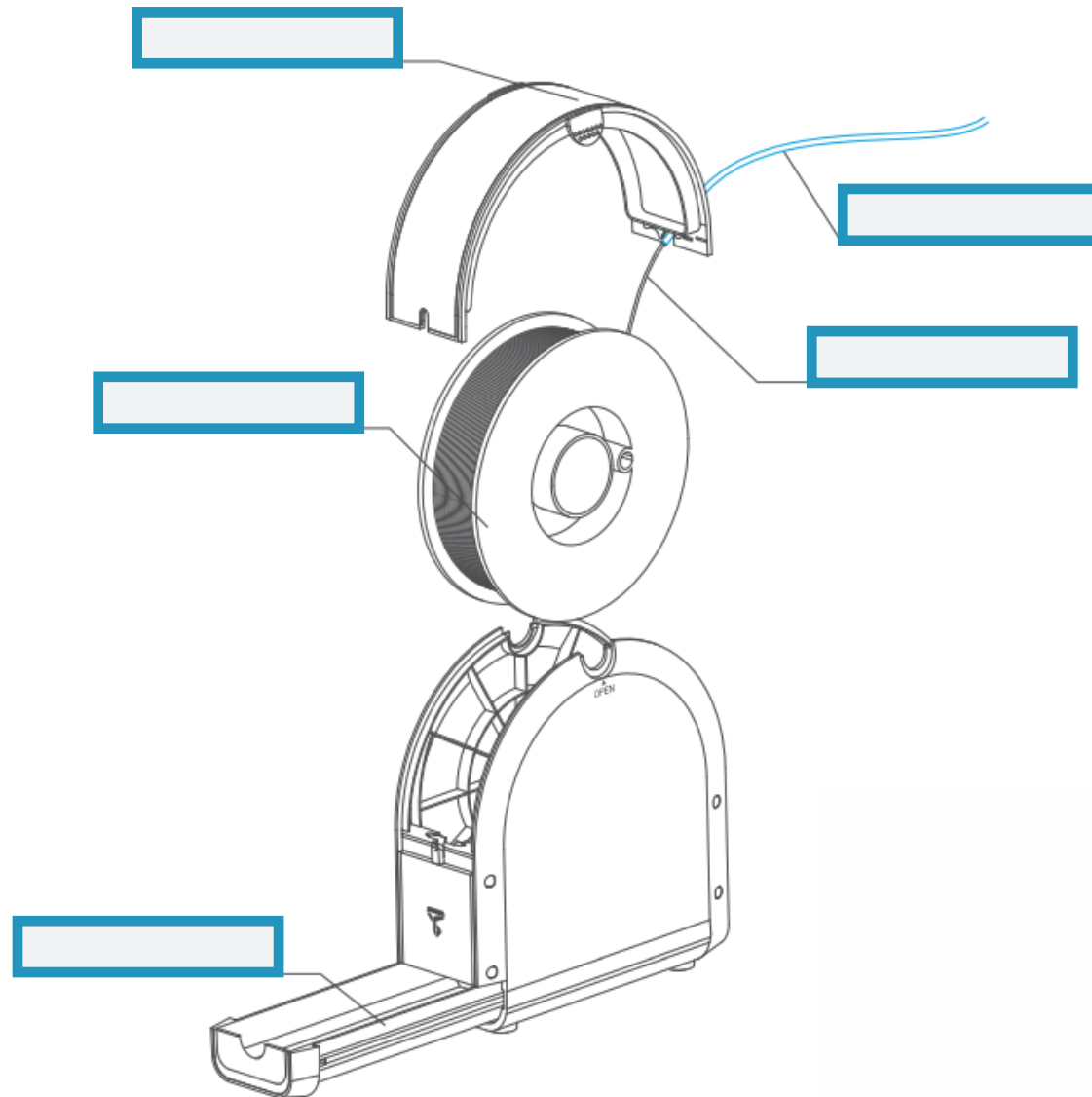

COMPONENTS

Filament

Filament Spool

Spool Holder Lid

Tool Drawer

Filament Guide Tube

ACTIVITY 4 - IDENTIFY 3D PRINTER COMPONENTS

Front Side

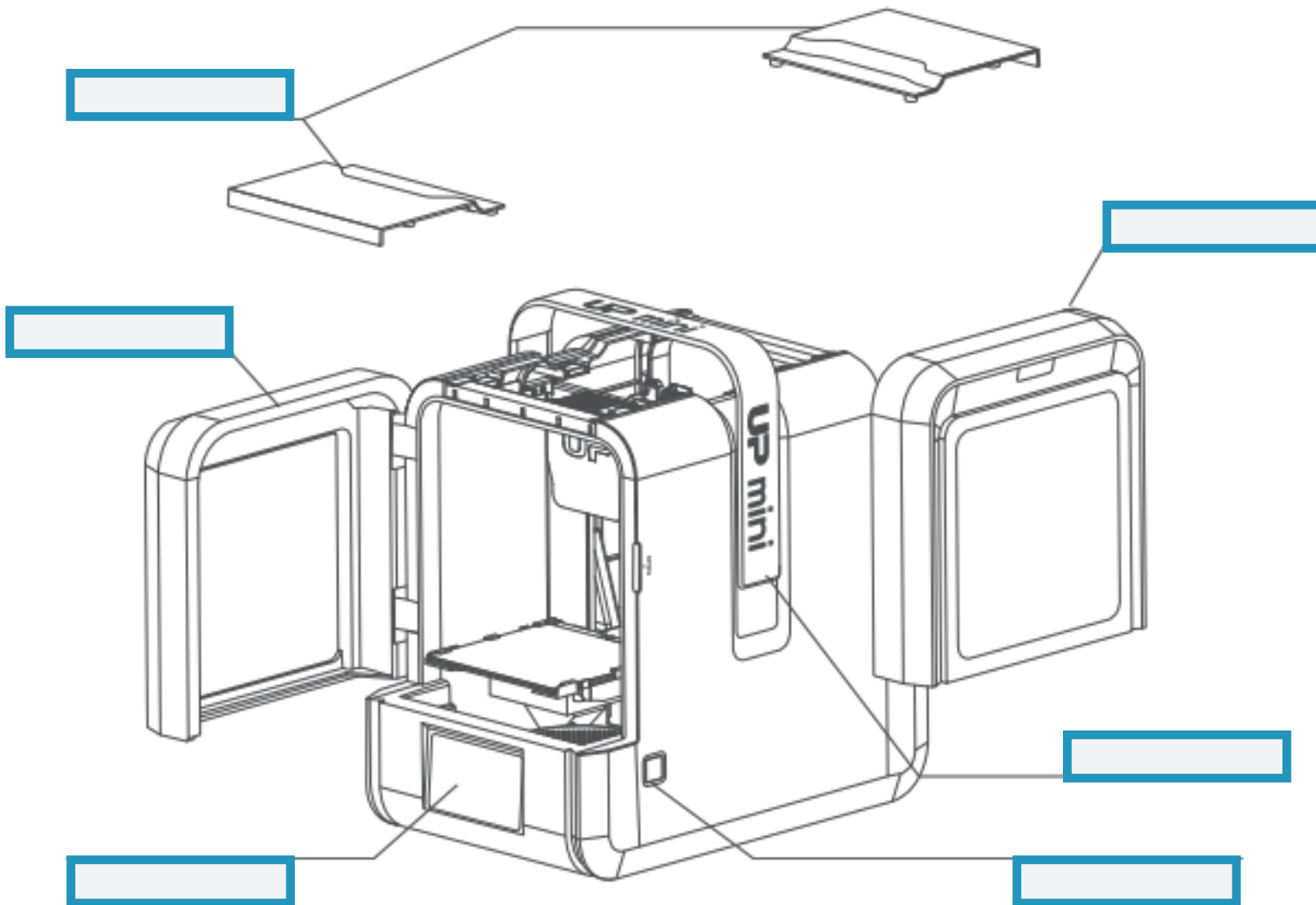

COMPONENTS

Back Door

Handle

Magnetic Top Lids

Front Door

LCD Touch Screen

Initialisation Button

ACTIVITY 5 - IDENTIFY THE INTERNAL COMPONENTS

Using the list of components on the right, identify each part by writing it in the relevant box.

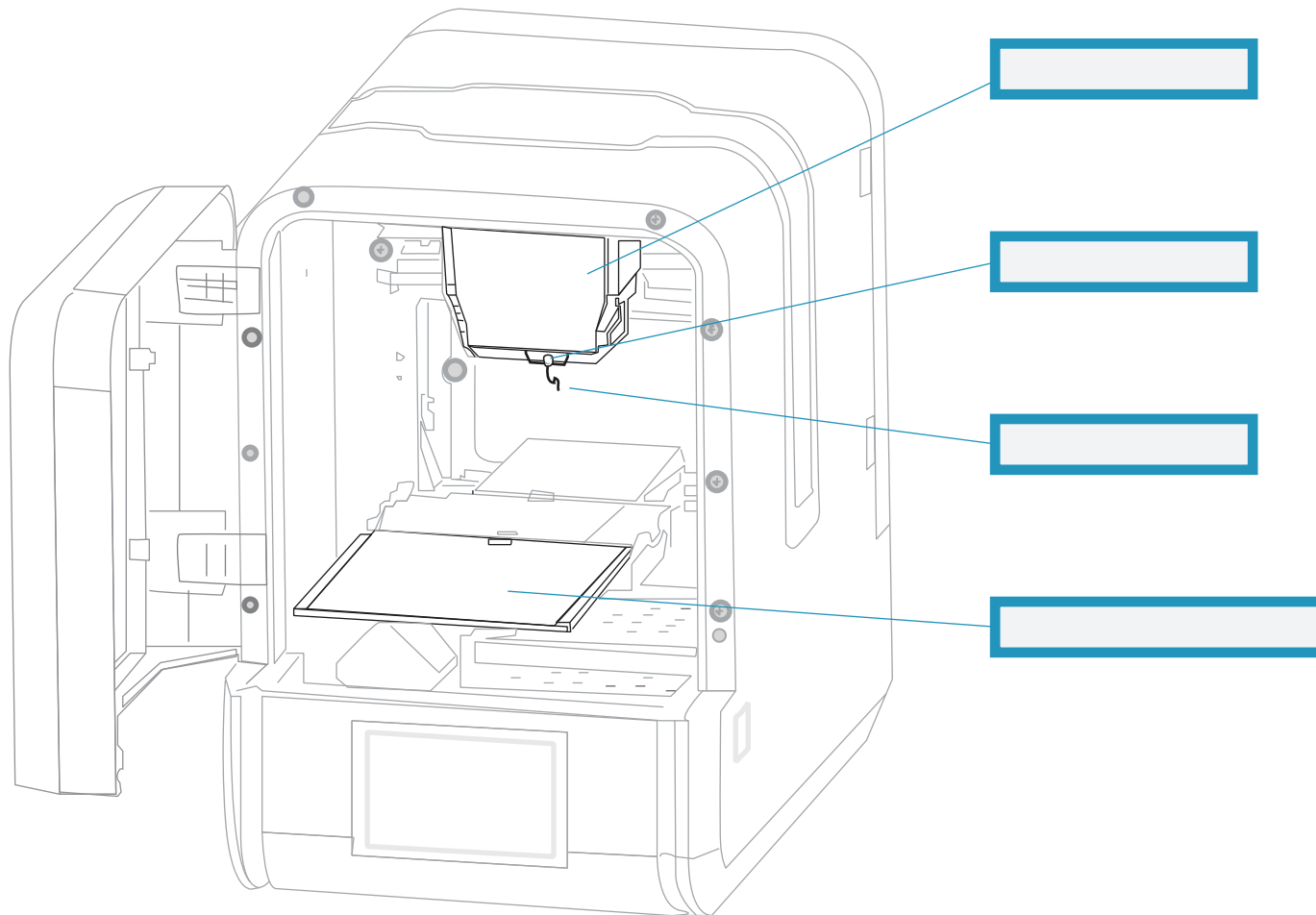

COMPONENTS

Print Head

Nozzle

Filament

Print Bed / Perfboard

ACTIVITY 6 - IDENTIFY 3D PRINTER SAFETY/OPERATIONAL TIPS

Using the safety tips on the right, identify what component it relates to by writing the safety tip number in the relevant circle.

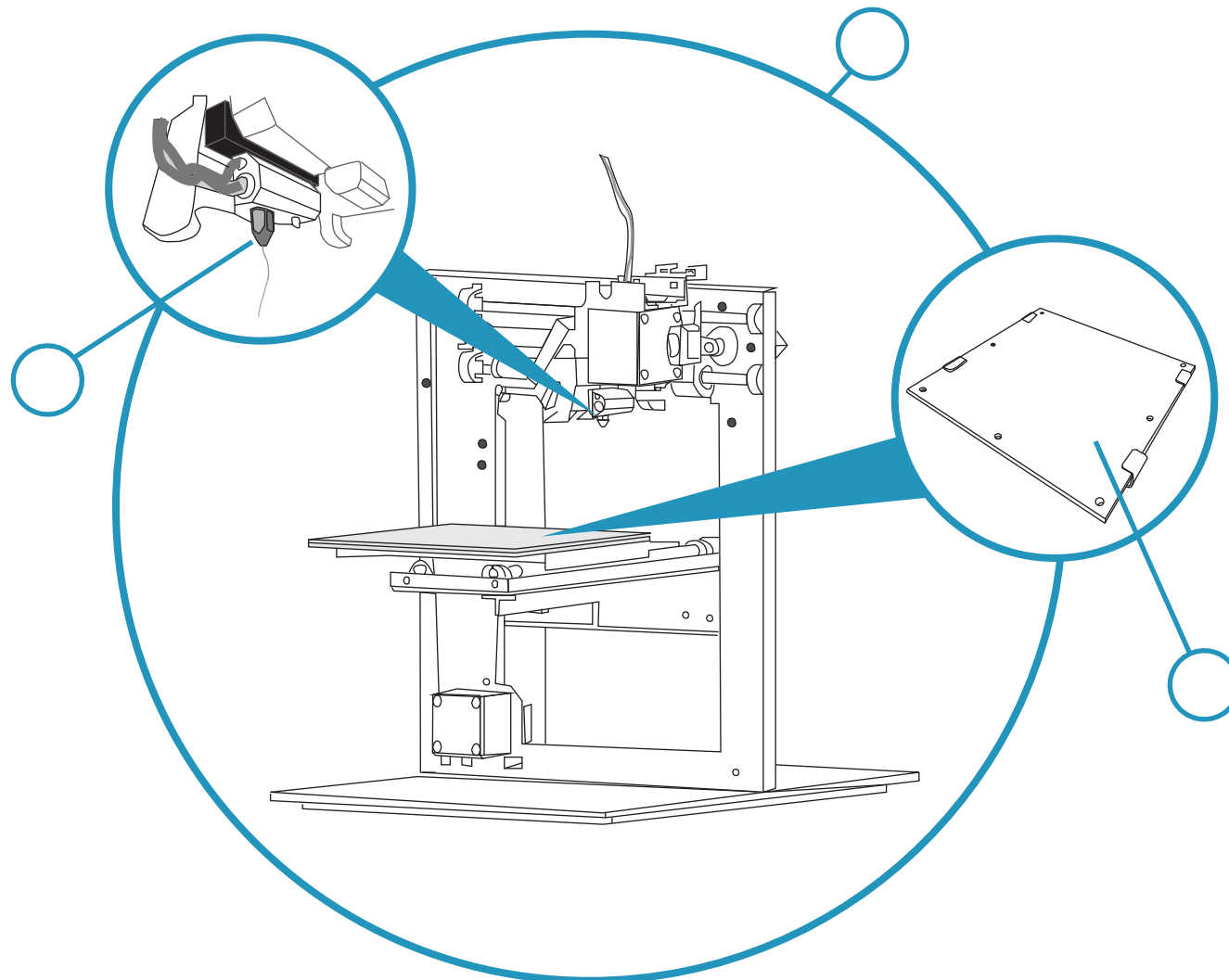

SAFETY/OPERATIONAL TIPS

- 1 Crush Hazard! Moving parts don't stop for fingers
- 2 250°C+ This will burn. Turn off & allow to cool before handling
- 3 Replace perfbord carefully. If steppers slip the print will need to be reinitialised

ACTIVITY 7 - 3D PRINTER WORKFLOW

We've identified four key stages in the 3D printing process. Each stage is listed below, with a number of consecutive steps. Put each step in the correct order, by placing a number in the corresponding circle.

1. GET THE 3D PRINTER READY

- Check the 3D printer is extruding correctly
- Switch on and initialise the 3D Printer in Up Studio App
- Check there is enough filament to complete the print
- Insert the perfboard into the print bed

2. PREPARE YOUR DESIGN FOR PRINTING

- Orient, scale and place model for efficient printing
- Import the CAD model into the UP! software
- Design a model in CAD and export for printing

ACTIVITY 7 - 3D PRINTER WORKFLOW CONTINUED

3. PRINT YOUR MODEL

Monitor the print job

Select print options and execute print

If the print is failing, abort the job

4. REMOVE YOUR JOB

Weigh, pay and takeaway

Clean up perfboard, ready for next use

Remove completed print from perfboard

PEER ASSESSMENT

I confirm that the observations of my peer showed active participation in this induction workshop and demonstrated a satisfactory understanding, including competent and safe use of the above tools.

Date	Peer Assessor	Peer Assessor Signature
------	---------------	-------------------------

FACILITATOR WORKSHOP OBSERVATION

I confirm that the observations made of the participant and active participation in this induction workshop demonstrated a satisfactory understanding, including competent and safe use of the 3D printer.

Date	Edge Facilitator	Facilitator Signature
------	------------------	-----------------------

PARTICIPANT DECLARATION

I declare the assessment above was my own individual work.

Date	Participant Signature
------	-----------------------