



Edge Lit Acrylic

SLQ Wiki Fabrication Lab 2024/08/18 07:22

Edge Lit Acrylic



Mick Byrne, Aug 2024

Acknowledgement

We acknowledge Aboriginal and Torres Strait Islander peoples and their continuing connection to land and as custodians of stories for millennia. We respectfully acknowledge the land on which we all meet today, and pay our respects to elders past, present and emerging.

Summary

Edge Lit Acrylic Signs was developed and delivered at 2 Family Maker Club Sessions in July and August 2024. In the First workshop participants learned how to create artwork and then laser etch & cut

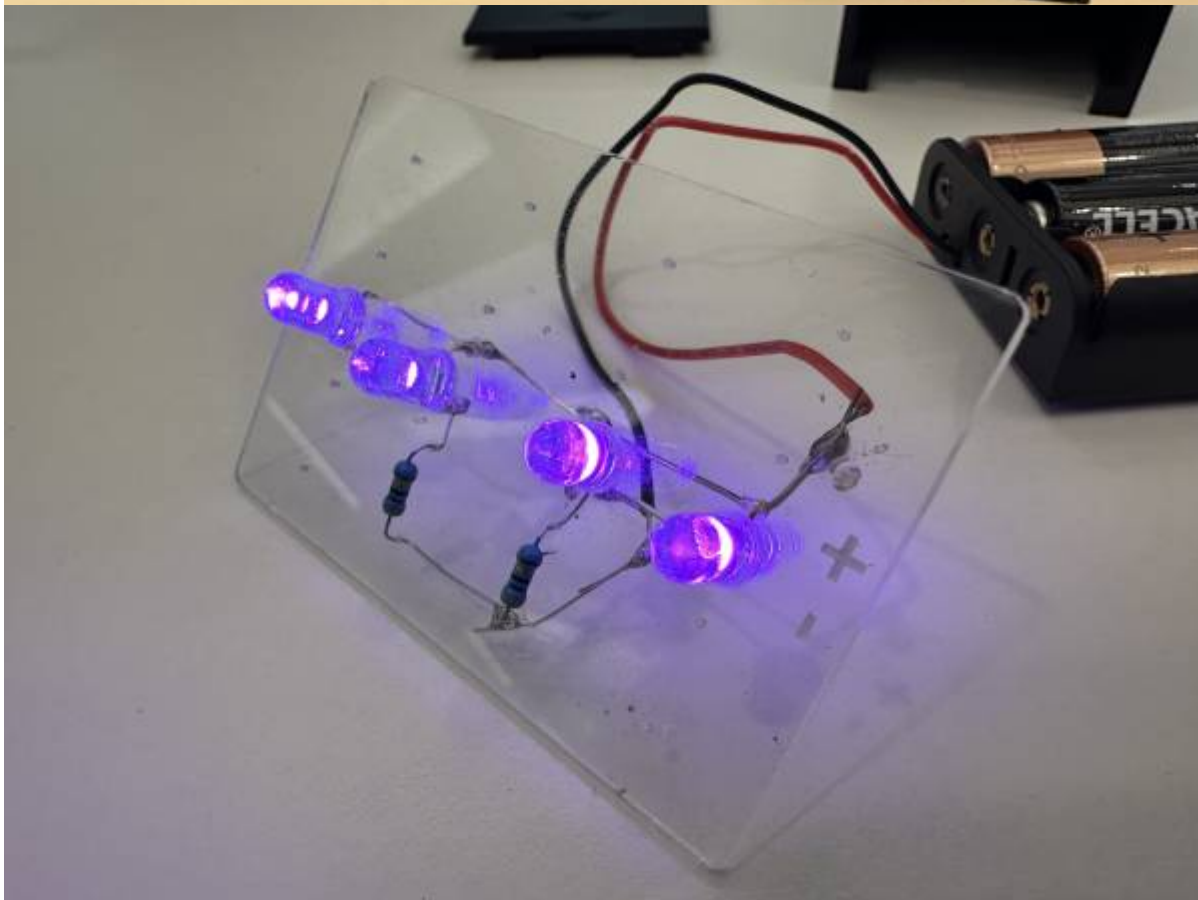

Skills Introduced

- Bitmap and Vector Image manipulation (PS & AI) - import image, convert to grey scale, invert and isolate negative space
- Laser cutting
- intro to electronics
- intro to soldering

and for extension if you have time basic CAD and 3D printing

Materials

If your workshop does not require any materials (maybe digital only) delete this section or change to something more appropriate.

Material	Quantity	Cost	Supplier
LEDs	4	\$0.40	Supplier 1
47 R resistor	2	\$0.70	Supplier 2
Battery box	1	\$1.30	Supplier 2
AA battery	5	\$3.00	Supplier 3
10mm Acrylic	1	\$6.00	Supplier 3
3d Printed Plinth	1	\$6.00	Supplier 3
	Total	\$17.40	

Tools and Preparation

Again, if your workshop does not require physical tools, delete or change this to something like Software required.

Tools

- Tool 1
- Tool 2
- Tool 3
- Tool 4

Preparation

Before the workshop you will need to ...

Workshop Walk through

Workshop 1

Step 1

Welcome and Tour

Step 2

Laser Demo

Step 3

Artwork Demo

Step 4

Participants decide on an idea

Step 5

Participants prepare artwork

Step 6

Participants prepare and cut artwork on laser.

Workshop 2

Step 2-1

Welcome and Tour

Step 2-2

Intro to Electric Circuits (conduct a scaled down version of [Electronics 101](#)) with a special focus on:

- Current flow - Atoms passing their free electron from Neg to Pos
- LEDs - Polarity
- resistors - Restricting the flow of current in the circuit.

Step 2-3

Demonstrate building the circuit in Fritzing [edge_lit_acrylic.fzz.zip](#)

Start by showing what happens if you dont have the resistors [edge_lit_acrylic_no_resistor.fzz.zip](#)

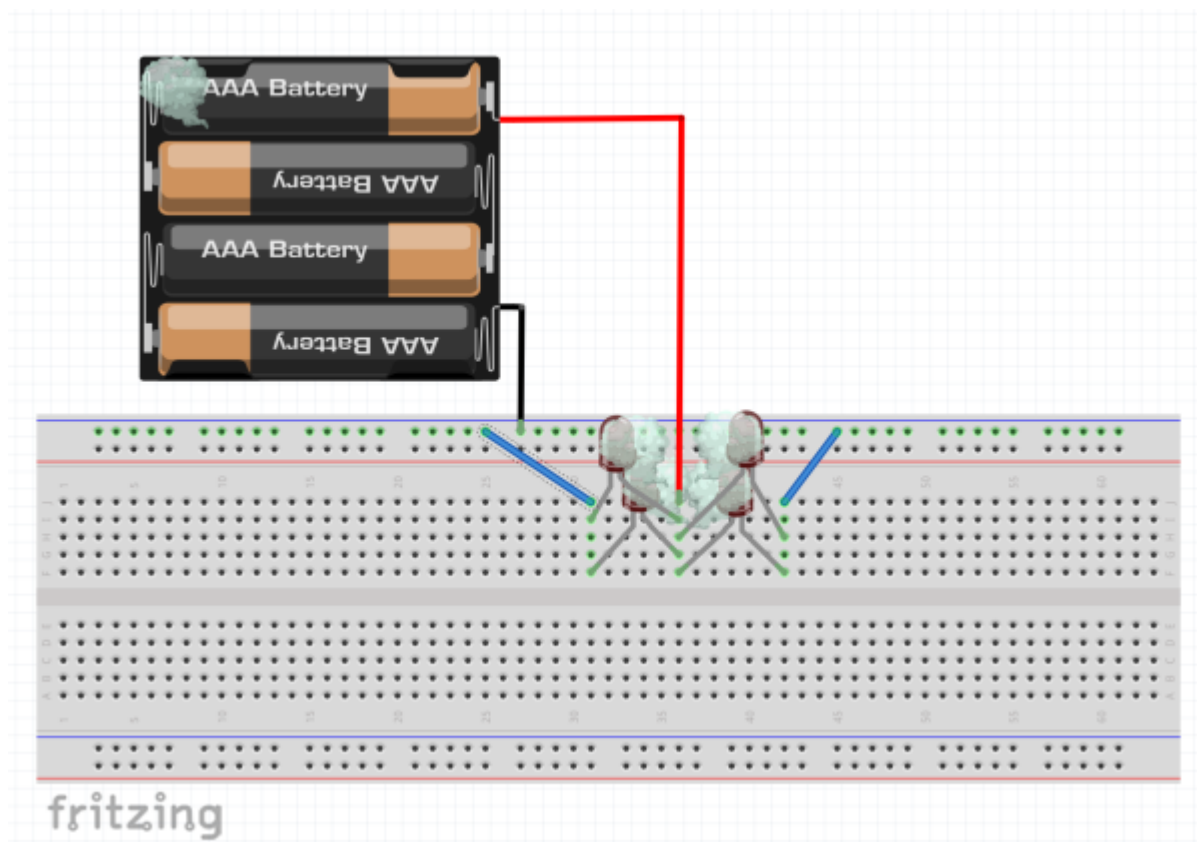

Step 2-4

Look at <https://ledcalculator.net/> for their suggestion for 4 LEDs with 4.7V

and then add the resistors in Fritzing

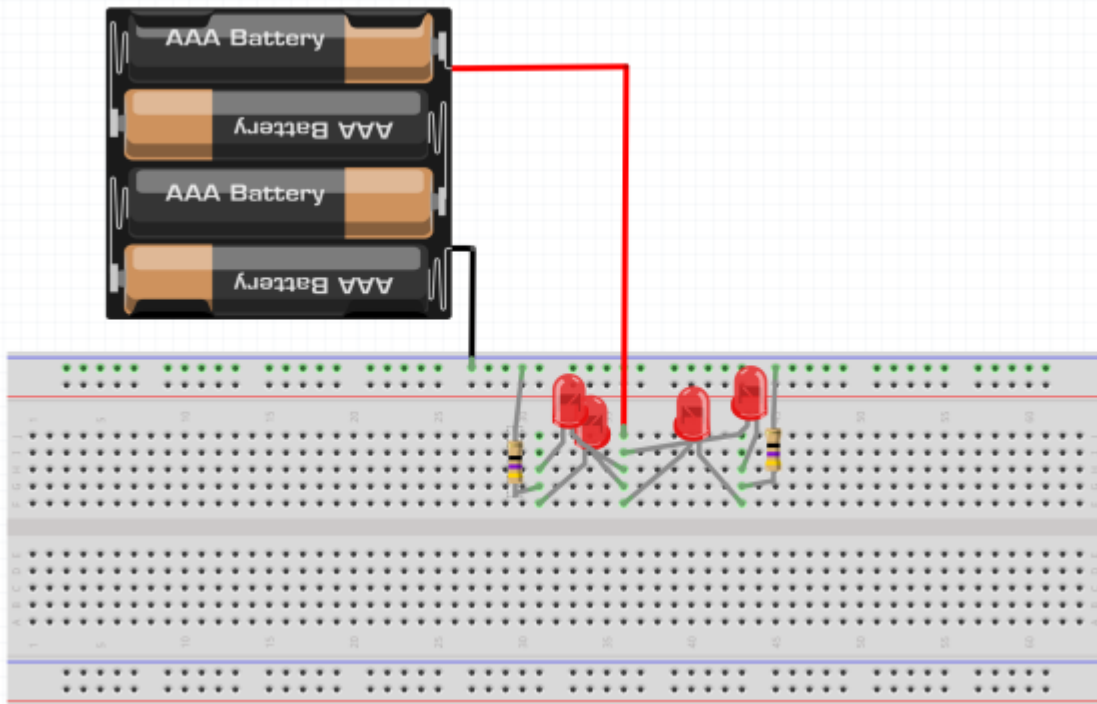

and show the outcome

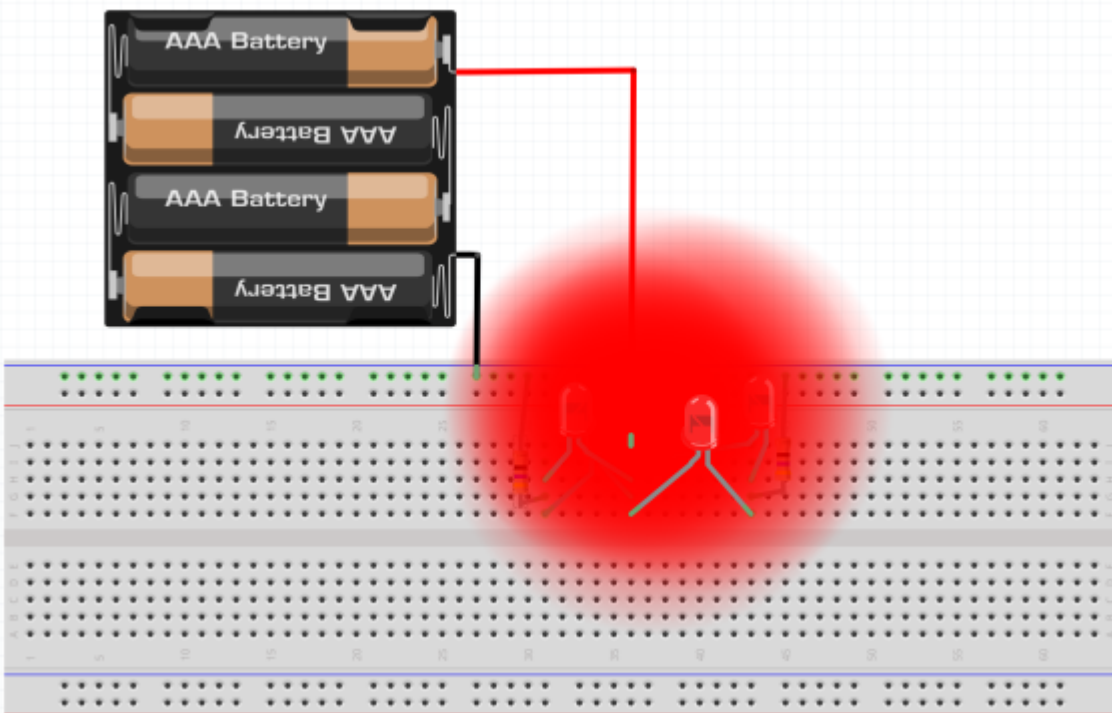

Step 2-5

Show how the current flows on the positive and negative sides of the circuit

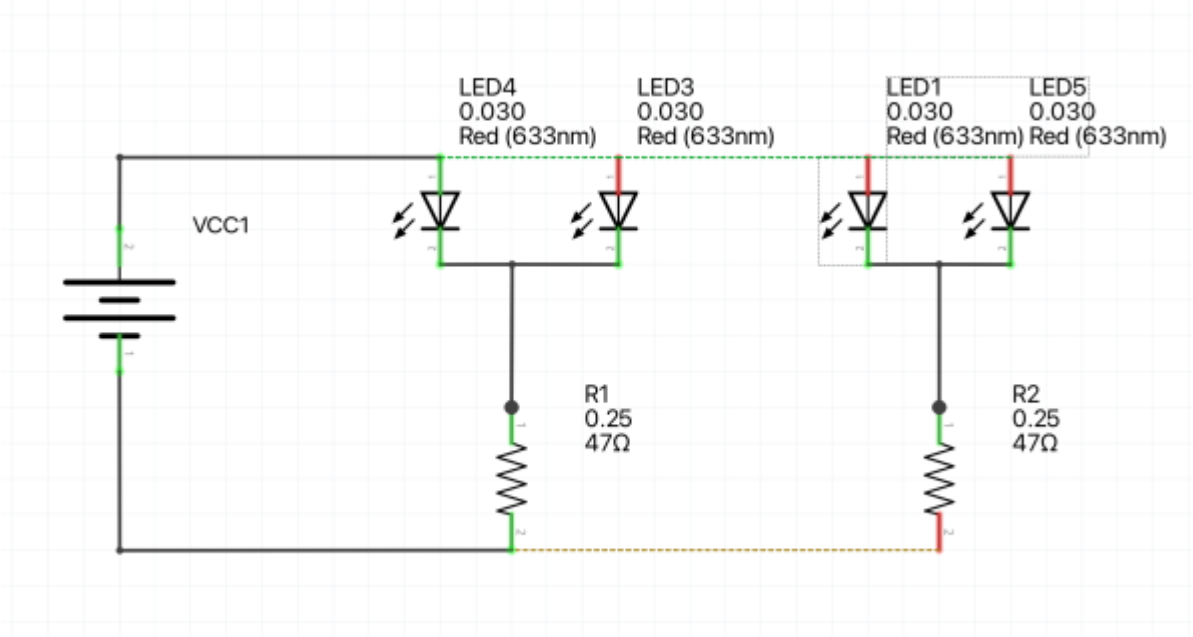

Positive across the top and negative from the bottom via each of the resistors

Step 2-6

Participant place their components in the circuitboard board.ai

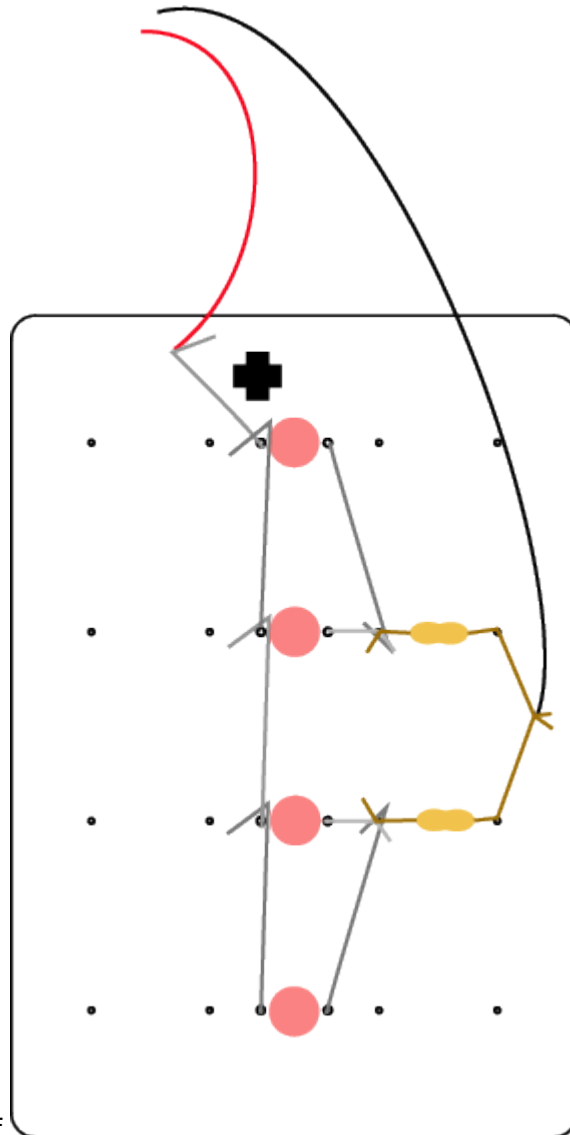

and using a print out of

Hints

1. add your leds and working from the back of the circuit fold positive legs around the next LED.
2. Then add your 2 resistors and then fold your negative led legs to connect these up.
3. Finally connect the positive and negative sides up to the leads on your battery box
4. Test you have you have LED Polarity right with a coin cell battery as you go

Step 2-6

finish up by soldering all your joints together and then trim the loose legs so they don't cause a short.

Step 2-7

Put your circuit and batterybox in the Plinth that steve designed for 3D printing.

[edge_lit_acrylic_sign_end_cap_rev_d.stl](#)

[edge_lit_acrylic_sign_main_housing_rev_d.stl](#)

References

Downloads