



# **2023 delivery: Laser cut covers, hand sewn spines**

**SLQ Wiki Fabrication Lab 2024/09/01 08:52**

# 2023 delivery: Laser cut covers, hand sewn spines



Prototype developed by Billie Reuen 2021, workshop developed by Mick Byrne and Sarah Winter, October 2022

## Acknowledgement

We acknowledge Aboriginal and Torres Strait Islander peoples and their continuing connection to land and as custodians of stories for millennia. We respectfully acknowledge the land on which we all meet today, and pay our respects to elders past, present and emerging.

## Summary

This workshop was originally developed as part of the Great and Grand Rumpus in 2021. Applied Creativity team members Mick Byrne and Sarah Winter have redeveloped the workshop for delivery in 2022. The workshop series is delivered over 3 sessions of 4 hours each.

In typical Edge style, we have taken the traditional handcraft of bookbinding, and combined it with the contemporary skills of digital fabrication. At the end of these three sessions, participants created their own A5 journal with a hand sewn signature block using traditional methods learnt from the in-house State Library preservation team. During the workshop participants also learnt how to design a custom cover using Inkscape, which was cut using the Edge's laser cutter.

## Skills Introduced

Through the 3-part workshops series you will learn how to:

- Design a cover in Inkscape (vector graphics software)
- Cut and etch that design on our laser cutter (including a laser cutter induction)
- Sew up a text block from loose leaves of paper using traditional materials and methods
- Turn our laser-cut pieces into a cover and complete our books.
- Bookbinding vocabulary and tools

## Overview

### Session 1

- Folding and punching text blocks
- Sewing signature block
- Learning illustrator basics
- Starting cover design (to be finished and emailed as homework before Session 2)

### Session 2

- Glue spine
- Laser cutter induction
- Glue ribbon, headband and mull
- Attach book cloth (we will pre-cut your book cloth)
- Pressing book

### Session 3

- Add end papers
- Decorate cover (including gold leaf)
- Pressing book

# Session 1

## Session 1

Design, Illustrator and sewing

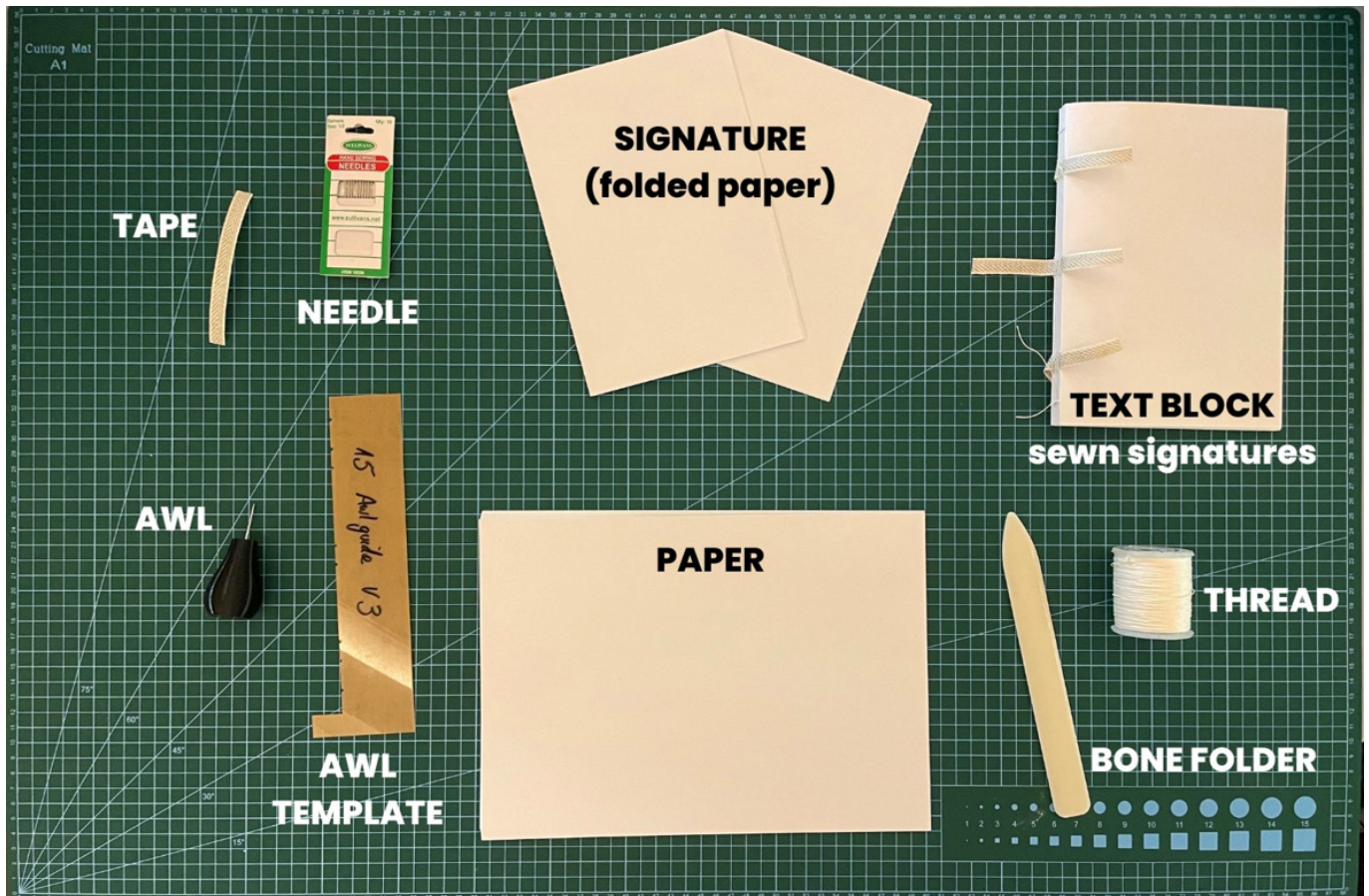

### Objectives for first session

- Check everyone has signed in and their SLQ logins are working
- Why did you sign up? what are you hoping to get out of this series? Has anyone had any experience with bookbinding before?

### Materials for first session

We will be working through [these slides](#) in the first session. You will also need the following materials:

- Paper for book pages (we used A4 folded in half for the A5 journal)
- Waxed cotton thread

- Sewing needles (we used embroiders needles to get a large enough eye for the cotton)
- A bone folder
- An awl for punching the holes
- An awl guide - [a5\\_awlguide\\_v3.ai](#)
- Bookbinders tape
- illustrator program
- We also used Nightcafe to generate some of our front cover art. Night cafe is an AI art generator. <https://nightcafe.studio/>

## Welcome

- Check everyone has signed in and their SLQ logins are working
- Why did you sign up? what are you hoping to get out of this series? Has anyone had any experience with bookbinding before?

## Hand sewing spines

Today we will be folding and sewing our text block.

### Folding and punching the signatures

We will be creating a journal that is made up of 6 signatures in total, with 6 folded A4 pages making up each signature. This means that we will have a total of 72 pages in our journal.

#### Step 1

Gather your pages into 6 lots of 6 pages. Fold each lot of 6 in half to create a signature. Use your bone folder to reinforce the crease and give a crisp fold.

#### Step 2

Once you have folded your signatures, take your awl guide, and positioning it in the fold of the paper, puncture holes in each of the diverts on the guide. We found that having the paper on something like cardboard allows more give for a cleaner hole punch. We also suggest that you punch at a 45 degree angle to ensure the holes line up in the paper.

### Sewing the text block

We have put together a video that guides you through the process of sewing your text block. Please note that this video is silent.

Video to be linked when hosted elsewhere

## Designing the front cover

We will be using the following template to design our book insert

`insert_bookbinding.ai`

The dimensions of your square/insert are locked at:

W= 154.803mm H = 112mm

In this workshop we will be using Adobe Illustrator to design your cover - but the principles of what you learn on this program is very similar to what you would do on a free software such as Inkscape.



There are two options for designing your front cover. You can start your design from scratch, or you can use an AI text to artwork generator. We've detailed the approach in each of the steps below.

### Getting started with Inkscape

You will first design your own front cover in A5 in Inkscape, and then copy across into the laser cut template below. To get you started with Inkscape, we have provided some introductory videos to get you familiar with the key tools.



### Inkscape Help

Inkscape can be tricky to start with but there is loads of info available to you! You can check out our wiki pages, both are full of guides, help and info: [Inkscape wiki page](#) [Vector Graphics wiki page](#)  
Or check out Inkscape's own resources; [guides community](#)  
Remember too, the power of google! Inkscape is very popular software and if you're asking how to do something, chances are someone else has before too.

I've also made some videos specific to the kinds of things we're doing in this session below ↓

### **Add and move shapes**

Adding simple shapes often makes up the foundation of a graphic.

[inkscape\\_addandmoveshapes2.mp4](#)

## Custom Shapes

Sometimes you want a shape or graphic that you can't find, and there are a few ways that you can make your own.

[inkscape\\_custom\\_shapes2.mp4](#)

## Colour and Style

Adding colour, borders and changing widths and weights of line allow you to personalise shapes more.

[inkscape\\_colourandstyle2.mp4](#)

## Converting Pixels to Vectors

To work with the laser cutter, you need to produce vector files. Some considerations when turning pixels into vectors.

[inkscape\\_bitmap\\_trace.mp4](#)

## Using a text to image AI generator

In creating our pirate ship book prototype we used Night Cafe <https://nightcafe.studio/>. We entered the description "Vector image of an ancient decorative book cover with a giant octopus attacking an old ship in 3 colours". The laser cutter needs the file to be set up using: 1. Red assigned to cut 2. Black assigned to etch 3. Other colour assigned to deeper etch (if required). We therefore reduced the image down to 3 colours in Inkscape and cleaned up the picture using the "trace bitmap" function

## Inspiration & Sources of royalty free artwork

[//Stencil Catalogue for the use of practical men//](#)

[Excelsior Fresco Stencils](#)

[250 Stencil Designs From India](#)

[Our colleague Billie Ruben's book covers pintrest board](#)

<https://stock.adobe.com/au/> Adobe Stock has a lot of free images and line drawings that you can use

[The Public Domain Review](#) The Public Domain Review is dedicated to the exploration of curious and



compelling works from the history of art, literature, and ideas – focusing on works now fallen into the public domain, the vast commons of out-of-copyright material that everyone is free to enjoy, share, and build upon without restrictions.

<https://publicdomainreview.org/collection/the-art-of-book-covers-1820-1914>

## Session 2

# Session 2

Gluing the spine, pressing the book and laser cutter induction

### Materials for first session

We will be working through [these slides](#) in the second session. You will also need the following materials:

- PVA glue
- Paint brush
- Ribbon for bookmark
- Headband
- Mull
- Book press
- Laser cutter
- Isopropyl alcohol and paper towel for cleaning laser cut cover

### Objectives for session 2

In this session you will be gluing together your text block and attaching your book ribbon, headbands and mull. You will also be inducted on the laser cutter. There is a lot of glue in this session, and you will be task switching a fair bit to work between the glue drying, and working through your laser cutter induction.

### Overview of book construction

In this session you will be beginning to construct your book using the signatures made last session. It is important to understand the elements of a book, and how it is constructed.

# Overview book construction

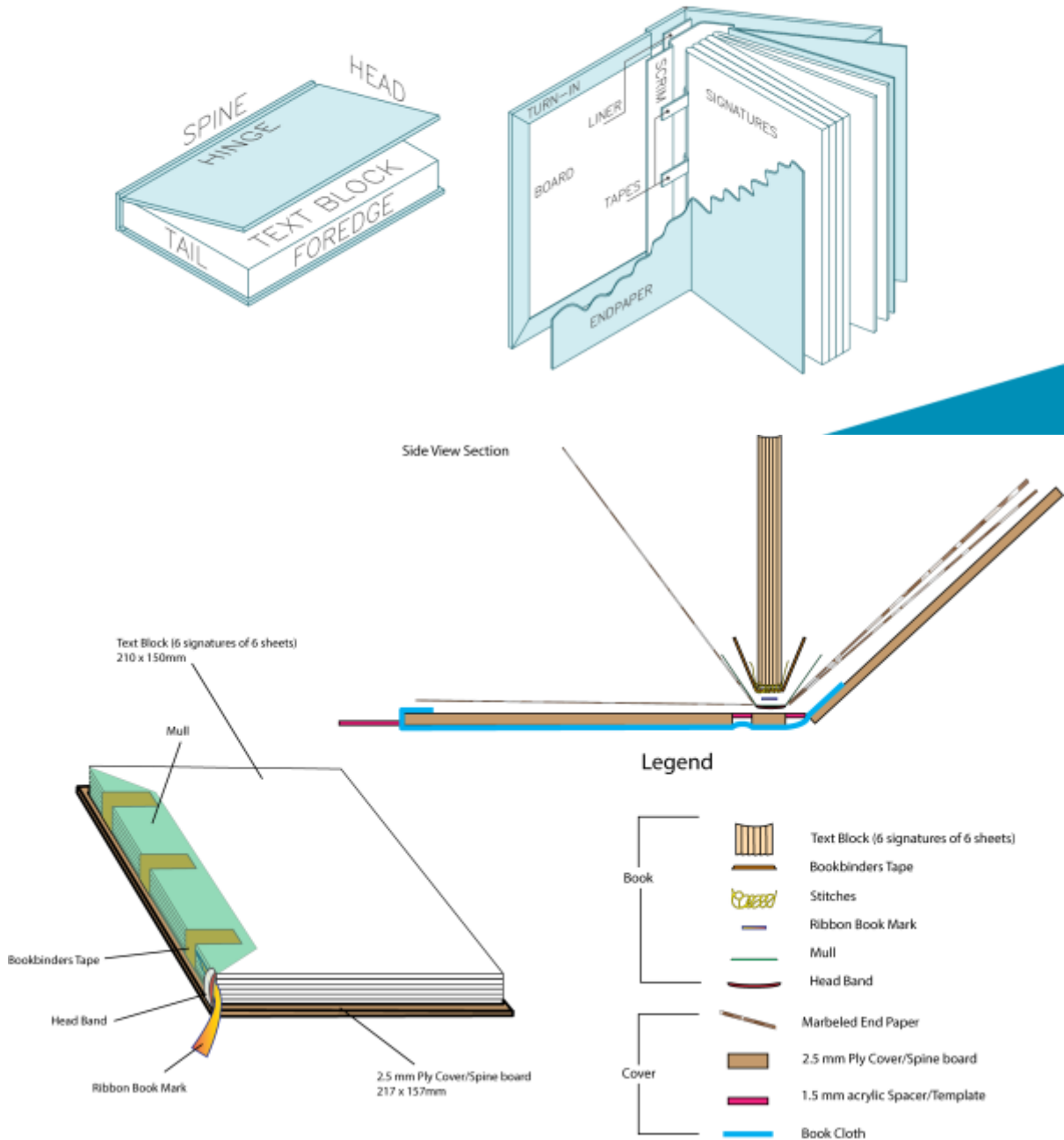

Today you will be gluing your signature block to reinforce it. You will be then gluing on your ribbon and headbands which sit at the head and tail of the spine, underneath the scrim (also known as mull).

You will also need a book press for this session. At home you can use two pieces of thick (12mm +) ply wood and a woodworkers clamp. Alternatively, we made the following book clamps for the workshop.

## Making a book clamp

Purchase 19x90mm hardwood decking timber (less likely to bow) and some M6 100mm nuts and bolts to create a prototype of a simple book press. Press is very simple with 2 bolts for tightening. Designed and 3D printed a M6 Sleeve (stop timber jaws of press catching on thread of bolt and Thumb knob to go over the nut for hand tightening down the press. There is a chamfered side on one face for gluing and getting in close to the work, and a Flat side to stand the work up when required. Also features a lap knock for hooking press against bench when trimming text block manually with a chisel.

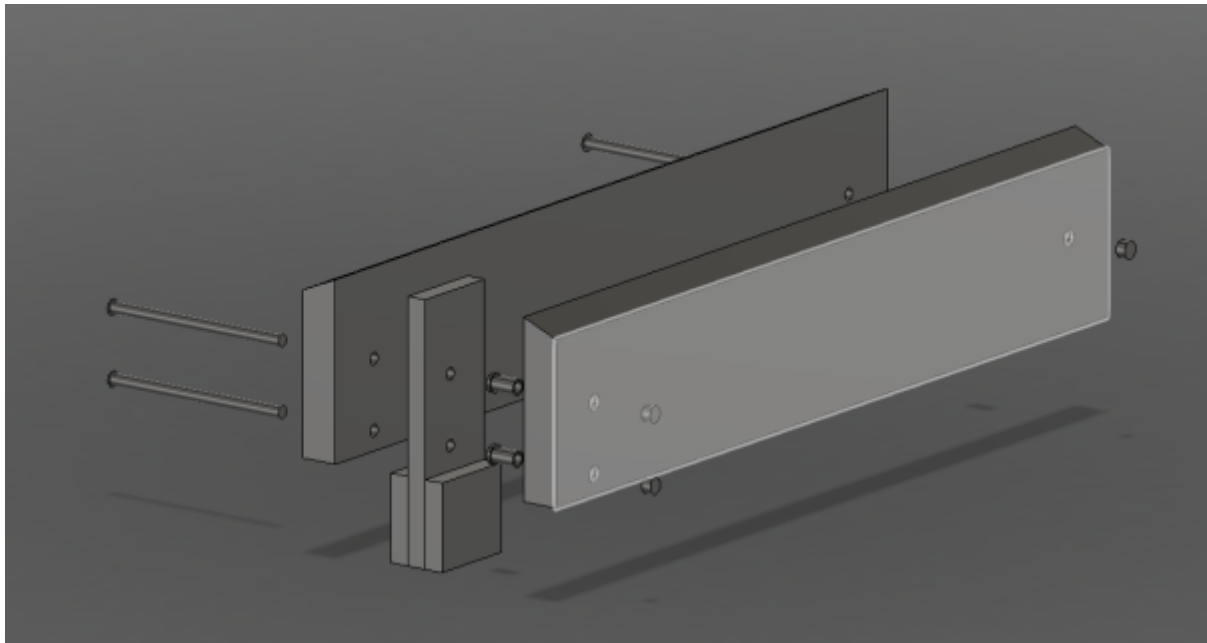

## Glue signatures

Today you will be gluing your signatures together to create a text block

- Place your signatures between thick card and knock against the table to ensure all the pages are lined up
- Place book in clamp (straight but with a little give) using the thick card to hold the signatures together. You should have the sewn ends sitting slightly proud to allow for gluing.
- Glue: Just gluing the spine and leaving the tapes glue free at the moment (we'll glue these when we glue the mull)
- Leave to dry

## Choosing your materials

While the spine of our book dries, you will next choose your materials and colours. You will need to choose:

- Marbled paper
- Headband colour

- Bookmark ribbon colour
- Ink colour
- Book cloth
- Where gold leaf could be used.

Consider how the image on your front cover can be complimented by your choice of colour.

## **Laser cutter induction**

While your signature block dries, you will go and complete your laser induction.

## **Gluing on headband and ribbon**

- Cut 2 pieces of headband to width of text block
- Cut your ribbon the length of your book, with 2 extra inches.
- Glue to head and tail of spine sticking just out of the text block at each end

## **Cutting the Mull**

The mull needs to be cut so that it fits between the two headbands, and the width of the timber engraving.

## **Glue on the Mull**

- Cut it to fit between the two headbands.
- Pre fold it to the right size for your book.
- Add plenty of glue, dab it to saturate mull
- Smooth with finger
- Pull mull to ensure the glue is saturated through.

## **Clean up your cover**

Using paper towel and isopropyl we are going to remove some of the charring that happens with the laser.

Apply the isopropyl to the paper towel, and rub against the timber to remove the charring and clean the timber ready for applying the ink.

## **Experimenting with the ink for decoration**

It is helpful to experiment with the ink before applying it to your cover to test what the best application would be for the timber you are using, and how dark you want the stain to be.

- Get a piece of timber offcut
- Practice different techniques for applying the colour.

1. Brush
2. Colour reduce (with water)
3. Wiping
4. Dabbing

Consider where you might want to gold leaf next session

## Session 3

# Session 3

Trimming pages, gluing end papers and decorating the cover

### Materials for first session

We will be working through [these slides](#) in the third session. You will also need the following materials:

- Ink for front cover
- End papers
- Gold leaf
- Gold leaf size
- Book press
- PVA glue
- Paint brush for ink
- Paint brush for glue
- Cups / containers for ink, glue and water
- Paper towel or rag cloth for wiping up work
- Book cloth
- Book template

## Other information and resources

### Laser cut and etch settings for the cover and spine

In the workshop we did a deep etch on 3mm Plywood from Plyco in a light Coachwood. Ensure that the grain is running in portrait mode (length ways) in order to avoid as much cupping in the timber.

## Etch

Power 90% Speed 90% 3 passes = 20 mins per A5 cover

## Cut

Power 100% Speed 1.6%

## Downloads

These files are used in the workshop.

When using the laser book binding template the process is: 1. Participant adds artwork and saves 2. Load artwork in ruby and etch cover and cut (deselect magenta etch for inside of cover) 3. Flip (horizontally) over cover and place back in ply sheet. 4. Deselect artwork and etch magenta etch (inside front and back covers). This is for the binding tape and mull to sit within.

[awlguide\\_a5v2.pdf](#)

[a2\\_laser\\_template.ai](#)

[scaled\\_assembly\\_diagrama5journal\\_2\\_.ai](#)

[laser\\_book\\_bindingtemps\\_laidout.ai](#)

[m6\\_nut\\_grips\\_and\\_sleeves\\_1\\_.stl](#)